

REV.	ECN.NO.	APPD.
A	/	/

NOTE:

- MATERIAL:  
HOUSING: LCP WITH 30% GF, UL 94V-0, BLACK COLOR.  
CONTACTS: PHOSPHOR BRONZE.  
BOARDLOCKS: BRASS.
- FINISH:  
CONTACTS: GOLD FLASH PLATED ON CONTACT AREA, [100μ"] MIN..  
BRIGHT-TIN ON SOLDER TAIL, WITH ENTIRE CONTACT UNDERPLATED [50μ"] MIN.. NICKEL.  
BOARDLOCKS: [100μ"] MIN. BRIGHT-TIN OVER[50μ"] MIN. NICKEL ON ENTIRE BOARDLOCK.
- PART NUMBER DESCRIPTION :

### ST21-0240-G618

G: 半金G/Fu"  
6: LCP  
1: 黑色

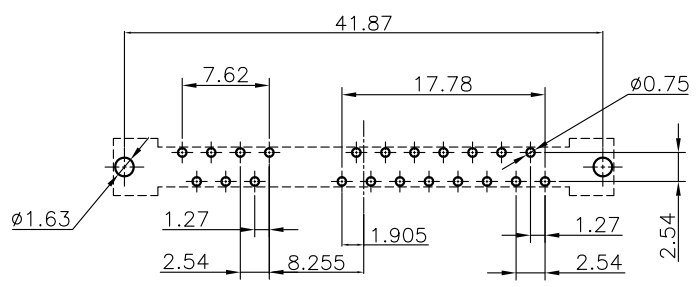
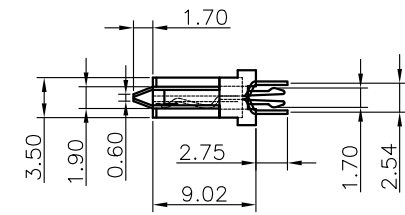
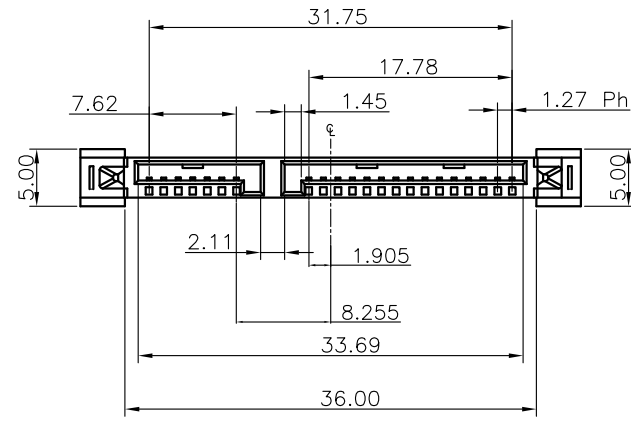
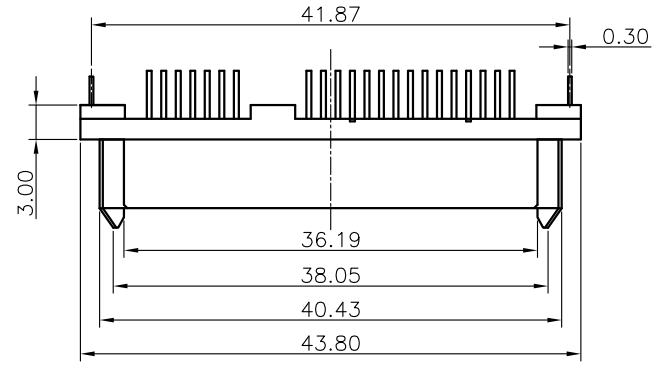

TOLERANCE: ±0.05,  
RECOMMENDED PCB LAYOUT  
(TOP VIEW)

TOLERANCE UNLESS OTHERWISE SPECIFIED		<b>FLW</b> 深圳市华联威电子科技有限公司			
.XXX ±0.10 .XX ±0.20 .X ±0.30		HUA LIAN WEI TECHNOLOGY ELECTRONICS CO;LTD.			
APPROVED		PART NAME:	SATA 7+15P 长体双排180度 PC2.75无凸鱼叉脚		
CHECKED		PART No:	ST21-0240-G618	C	
DRAWN	weihong	PROJECTION:	UNIT:	SCALE	SHEET
DATE	2021.9.23		mm	1:1	10F1
					REV. A