

REV.	ECN. NO.	APPD.
A0	/	/

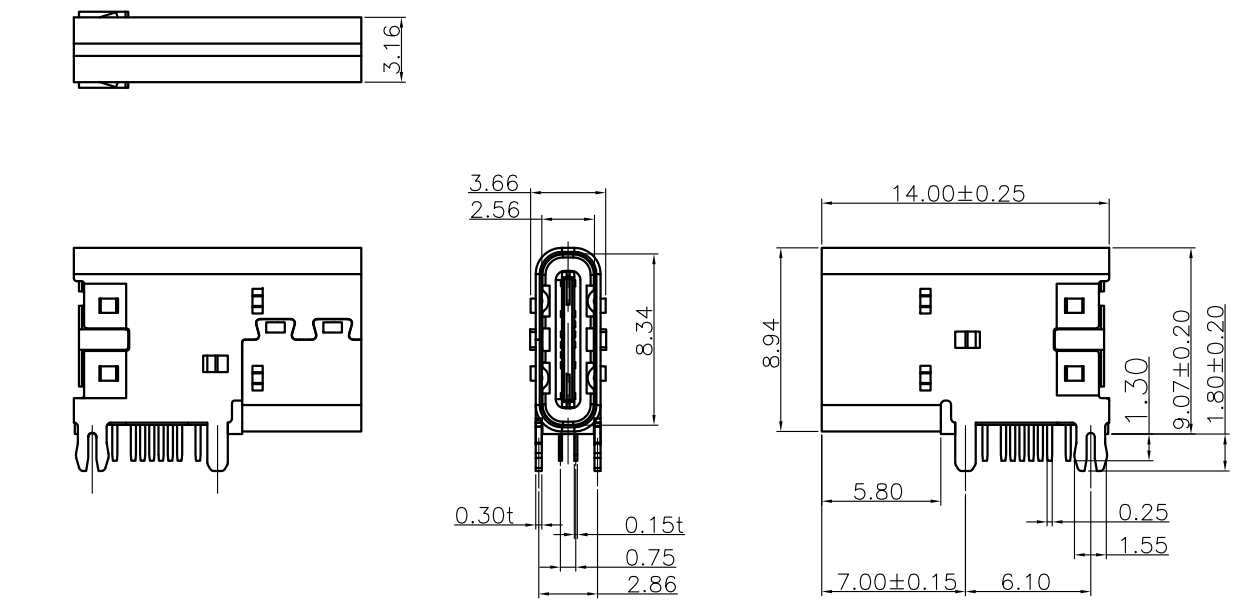

- NOTES:
- MATERIAL:
    - Housing:thermoplastic plastics
    - terminals:Copper Alloy  
Gold plated in contact area  
Tin plated in termination  
Nickel Plated overall
    - Shell:Steel&Copper Alloy  
Nickel Plated overall
  - ELECTRICAL CHARACTERISTICS:
    - Rating Current :1.5 Ampere
    - Rating Voltage :30 V Max
    - Contact Resistance:30 Milli ohms
    - Insulation Resistance:1000 Mega ohms Min.
  - MECHANICAL CHARACTERISTICS:
    - Connector Mating force: 35N MAX(3.57Kgf)
    - Connector Unmating force:10N min(1.02Kgf)
    - Durability:1500Cycles.
  - ENVIRONMENT CHARACTERISTICS:
    - Operating temperature:-0°C to +50°C
    - Storage temperature:-20°C to +60°C

U572-302B-XXX0X8

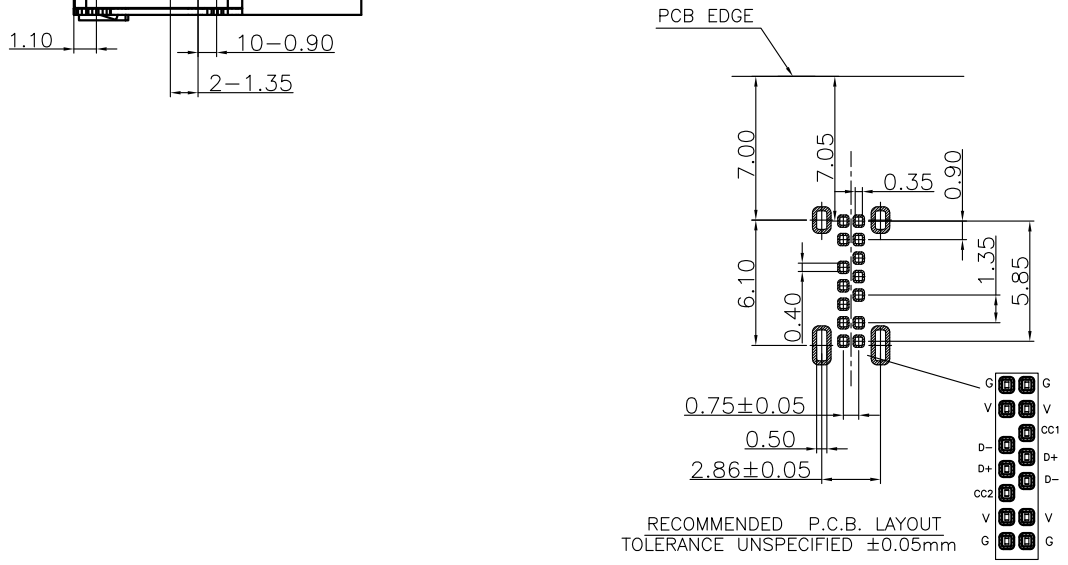
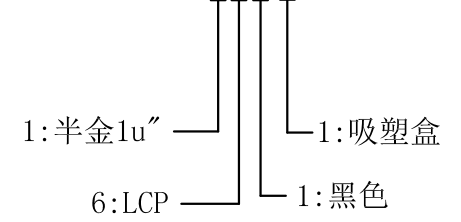

TOLERANCE UNLESS OTHERWISE SPECIFIED		<b>FLW</b> 深圳市华联威电子科技有限公司 HUA LIAN WEI TECHNOLOGY ELECTRONICS CO;LTD.					
.XXX ±0.10	.X° ±3°	APPROVED	PART NAME:	TYPE C 14P 侧插鱼叉脚 针长1.7			
.XX ±0.20	.XX° ±2°	CHECKED	PART No:	U572-302B-161018		C	
.X ±0.30		DRAWN	chenyiting	PROJECTION:	UNIT:	SCALE	SHEET
		DATE	2022. 10. 09		mm	1:1	10F1
							REV. A0