

REV.	ECN.NO.	APPD.
A	EXXXXXXXXXX	chenyiting

NOTES:

- SPECIFICATION:
 - CURRENT RATING: 0.5 A
 - CONTACT RESISTANCE: 30mΩ MAX.
 - DIELECTRIC WITHSTANDING VOLTAGE: 500V AC R.M.S FOR ONE MINUTE.
 - INSULATION RESISTANCE: 100MΩ MIN AT 500V DC.
 - OPERATING TEMPERATURE: -25° TO +85°.
 - DURABILITY: 10000 CYCLES.
 - MATING FORCE: 4.5KG MAX.
 - UNMATING FORCE: 1.0KG MIN

DP13-0715-G61018

- 5: 铜壳镀镍
- G: 半金G/Fu
- 6: LCP
- 1: 吸塑盒
- 1: 黑色

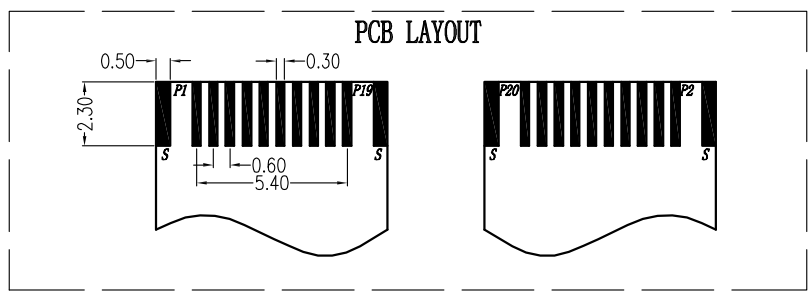
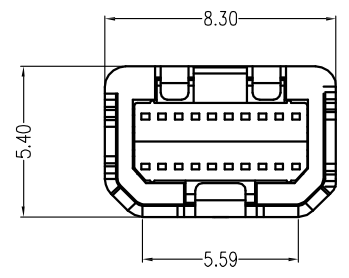
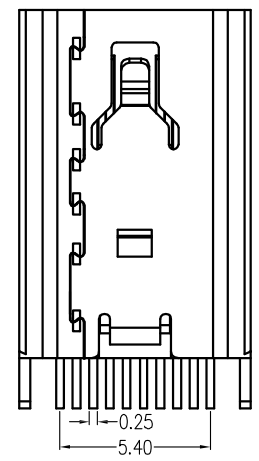
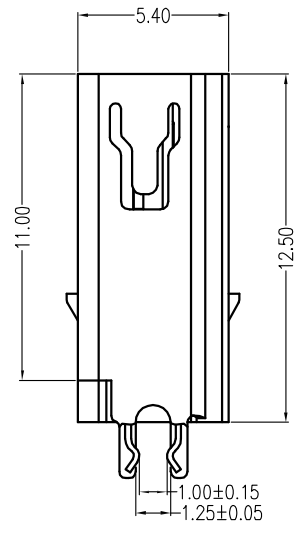
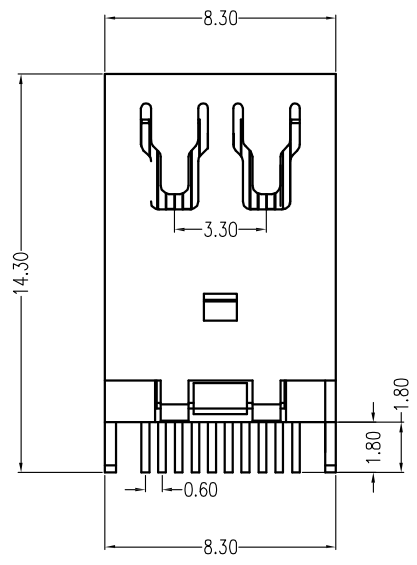
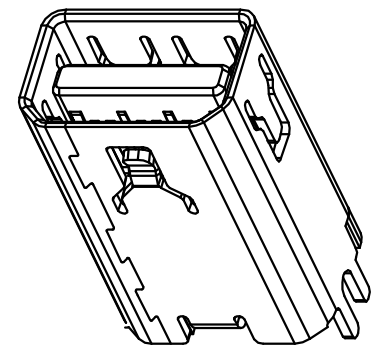
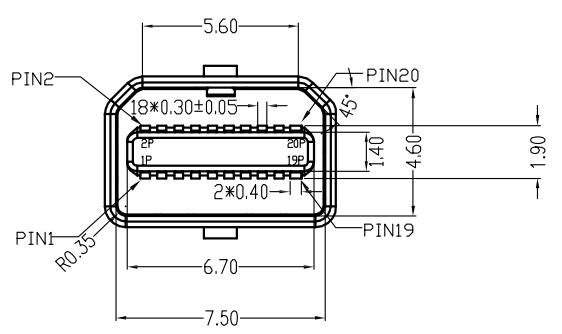

Top Row			Bottom Row		
Pin Number	Signal Type	Pin Name	Pin Number	Signal Type	Pin Name
1	GND	GND	2	In	HotPlug Detect
3	Out	ML_Lane 0(p)	4	CONFIG	CONFIG1
5	Out	ML_Lane 0(n)	6	CONFIG	CONFIG2
7	GND	GND	8	GND	GND
9	Out	ML_Lane 1(p)	10	Out	ML_Lane 3(p)
11	Out	ML_Lane 1(n)	12	Out	ML_Lane 3(n)
13	GND	GND	14	GND	GND
15	Out	ML_Lane 2(p)	16	I/O	AUX_CH(p)
17	Out	ML_Lane 2(n)	18	I/O	AUX_CH(n)
19	GND	GND	20	PWR Out	DP_PWR

TOLERANCE UNLESS OTHERWISE SPECIFIED		FLW 深圳市华联威电子科技有限公司 HUA LIAN WEI TECHNOLOGY ELECTRONICS CO.;LTD.			
.XXX ±0.10	.XX ±0.20	.X ±0.30	.X' ±3'	PART NAME: MINI DP母座夹板1.2	
.XX ±0.20	.X ±0.30	.X' ±3'	PART No: DP13-0715-G61018		C
APPROVED	chenyiting	PROJECTION:	UNIT: mm	SCALE: 1:1	SHEET: 1 OF 1
CHECKED	2023.05.22	DATE:	mm	SCALE: 1:1	REV. A