

REV.	ECN.NO.	APPD.
A	/	Andy.Pi

NOTES:

1. SPECIFICATION:
  - 1.1 CURRENT RATING: 0.5 A
  - 1.2 CONTACT RESISTANCE: 30mΩ MAX.
  - 1.3 DIELECTRIC WITHSTANDING VOLTAGE: 500V AC R.M.S FOR ONE MINUTE.
  - 1.4 INSULATION RESISTANCE: 100MΩ MIN AT 500V DC.
  - 1.5 OPERATING TEMPERATURE: -25° TO +85°.
  - 1.6 DURABILITY: 10000 CYCLES.
  - 1.7 MATING FORCE: 3.57KG MAX.
  - 1.8 UNMATING FORCE: 0.51~2.55KG

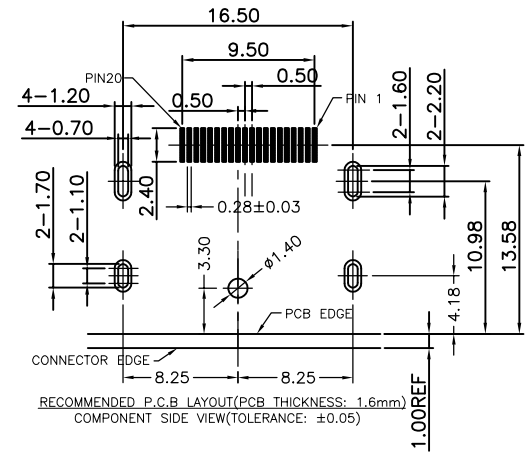
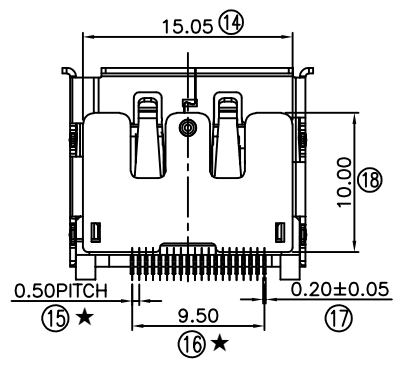
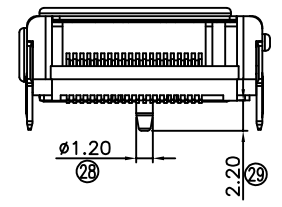
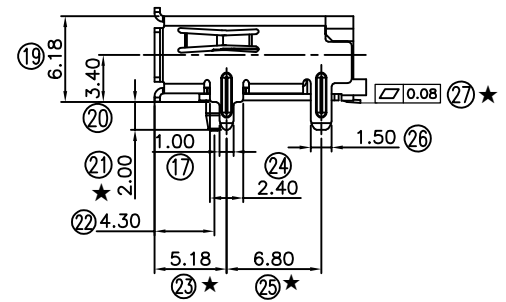
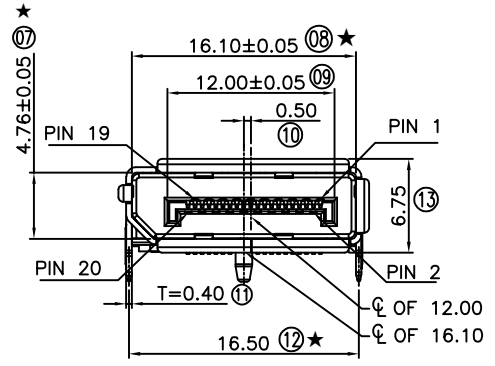
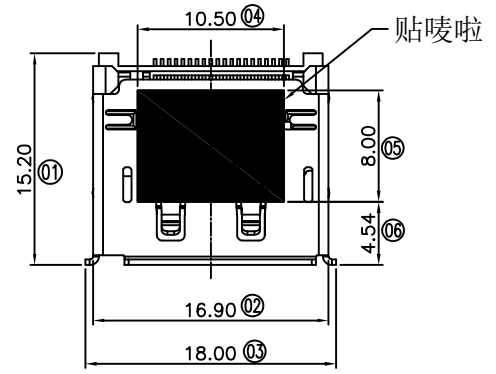
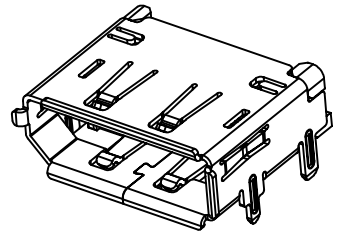

DP14-091X-G61081

- 1:铁壳镀镍
- 5:铜壳镀镍
- G:半金G/Fu
- 6:LCP
- 1:RoHS UL 94V-0
- 8:载带
- 1:黑色

TOLERANCE UNLESS OTHERWISE SPECIFIED		<b>FLW</b> 深圳市华联威电子科技有限公司			
.XXX ±0.05		HUA LIAN WEI TECHNOLOGY ELECTRONICS CO.;LTD.			
.XX ±0.10		.X' ±3'			
.X ±0.20		.XX' ±2'			
APPROVED		PART NAME:	DP 20P四脚插SMT无定位柱外壳有卷边		
CHECKED		PART No:	DP13-091X-G61081	P	
DRAWN	Andy.Pi	PROJECTION:	UNIT:	SCALE	SHEET
DATE	2023.09.15		mm	1:1	10F1
					REV.
					A