

REV.	ECN.NO.	APPD.
A	/	/

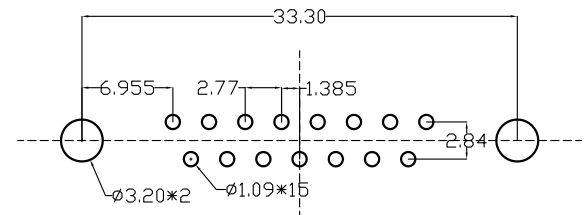
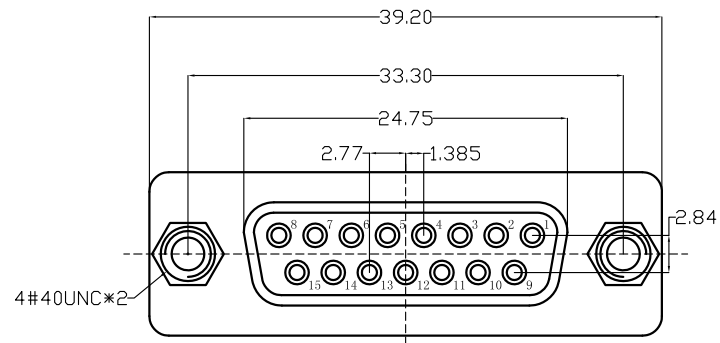

P.C.B LAYOUT

1.SPECIFICATION

- 2.1 Current Rate:5 Amps
- 2.2 Insulator Resistance:1000MΩ Min.
- 2.3 Dielectric Strength:500V AC PER MIN
- 2.4 Operation Temperature:-55℃~+105℃
- 2.5 Contact Resistance:30mΩ Max

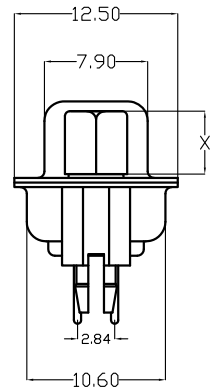
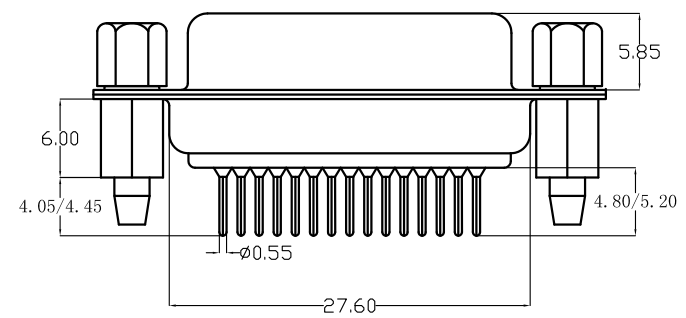

DS412-1410-G2H7

G: 半金G/Fu" H: 蓝色

2:PBT

螺丝规格

零件编号	X尺寸	内牙
5	4.8	4#40
6	5.8	4#40

TOLERANCE UNLESS OTHERWISE SPECIFIED		FLW 深圳市华联威电子科技有限公司 HUA LIAN WEI TECHNOLOGY ELECTRONICS CO;LTD.						
.XXX ±0.10	.XX ±0.20	.X ±0.30	.X' ±3'	.XX' ±2'	APPROVED		PART NAME: D-SUB 15/F 3.08	
CHECKED			PART No: DS412-1410-G2H7			C		A
DRAWED			PROJECTION:		UNIT: mm	SCALE: 1:1	SHEET: 10F1	REV. A
DATE								