

REV.	ECN.NO.	APPD.
A	/	/
B	/	/

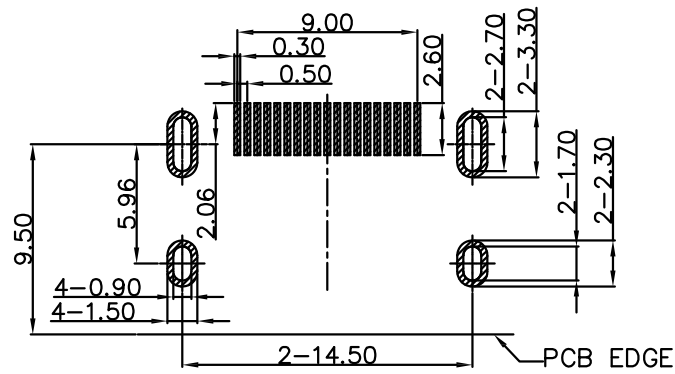
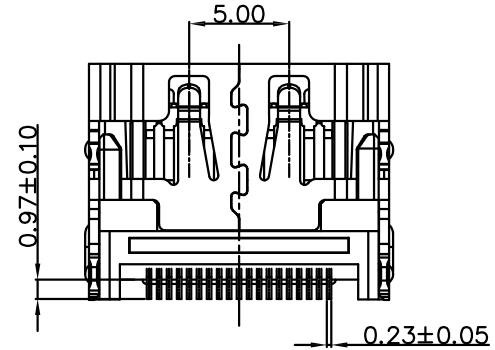
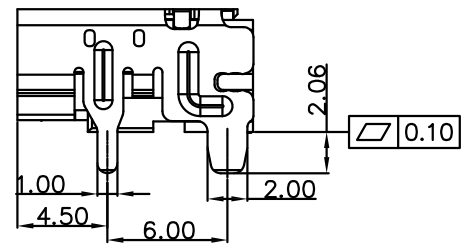
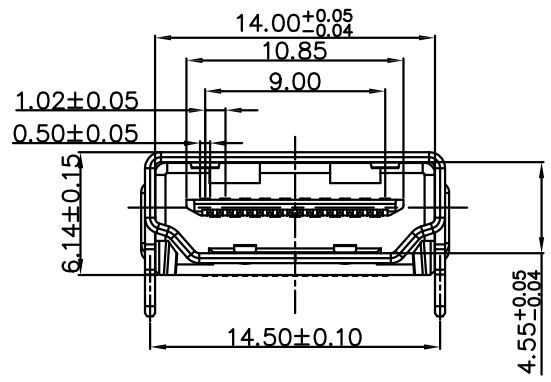
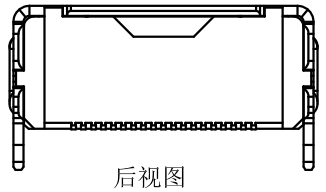
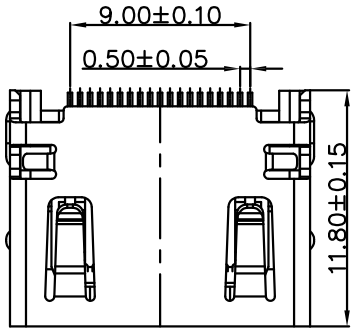

RECOMMEND PCB LAYOUT (T=1.00)
PCB TOLERANCE: ±0.05

NOTES:

- 1.MATERIAL:
 - 1.1 Housing:thermoplastic plastics
 - 1.2 terminals:Copper Alloy
Gold plated in contact area:
Tin plated in termination
Nickel Plated overall
 - 1.3 Shell:Steel&Copper Alloy
Nickel/Au Plated overall
- 2.ELECTRICAL CHARACTERISTICS:
 - 2.1 Rating Current :0.5 Ampere
 - 2.2 Rating Voltage :40 V Max
 - 2.3 Contact Resistance:30 Milli ohms
 - 2.4 Insulation Resistance:100 Mega ohms Min.
- 3.MECHANICAL CHARACTERISTICS:
 - 3.1 Connector Mating force: 4.5kg MAX
 - 3.2 Connector Unmating force:1.0Kg min
 - 3.3 Durability:10000Cycles.
- 4.ENVIRONMENT CHARACTERISTICS:
 - 4.1 Operating temperature:-20°C to +85°C
 - 4.2 Storage temperature:-20°C to +65°C

HD22-361X-XXX0X8
 1:Iron alloy
 Ni plating
 1:tray
 1:Black
 6:LCP
 G:“Au C/Fu”

TOLERANCE UNLESS OTHERWISE SPECIFIED		FLW 深圳市华联威电子科技有限公司 HUA LIAN WEI TECHNOLOGY ELECTRONICS CO;LTD.				
.XXX ±0.10	.X' ±3'	APPROVED	PART NAME:		HDMI 19P SMT带卡点, 不带凸点	
.XX ±0.20	.XX' ±2'	CHECKED	PART No:		HD22-3611-G61018 C	
.X ±0.30		DRAWN	weihong	PROJECTION:	UNIT:	SCALE
		DATE	2022. 10. 31		mm	1:1
					SHEET	REV.
					10F1	B