

REV.	ECN.NO.	APPD.
A	/	/

NOTES:
 1.MATERIAL:
 1.1 Housing:thermoplastic plastics
 1.2 terminals:Copper Alloy
 Gold plated in contact area:
 Tin plated in termination
 Nickel Plated overall
 1.3 Shell:Steel&Copper Alloy
 Nickel/Au Plated overall
 2.characteristics:
 2.1 Rating Voltage : 30V AC.
 2.2 Rating Current:
 5A for Vbus PIN;1.25A for Vconn PIN
 2.3 Contact Resistance:40 mΩ MAX.
 2.4 Insulation Resistance:100 MΩ MIN.
 2.5 Withstanding Voltage:AC 100V
 2.6 Mating force: 5~20N MAX
 2.7 Extraction force:8~20N Min
 2.8 Life test:10000Cycles MIN.
 2.9 Temperature Range: -30℃~+80℃.
 The product must be compliance ROHS

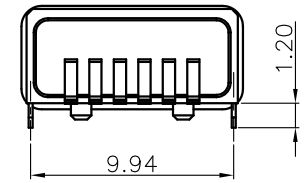

U573-061B-G61018
 B: 不锈钢镀镍
 G: 半金G/Fu"
 6:LCP
 1: 吸塑盒
 1: 黑色

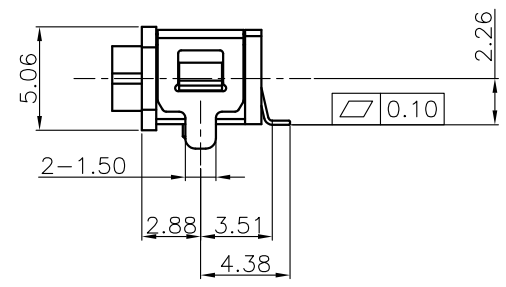
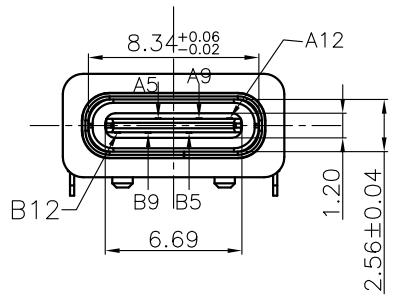
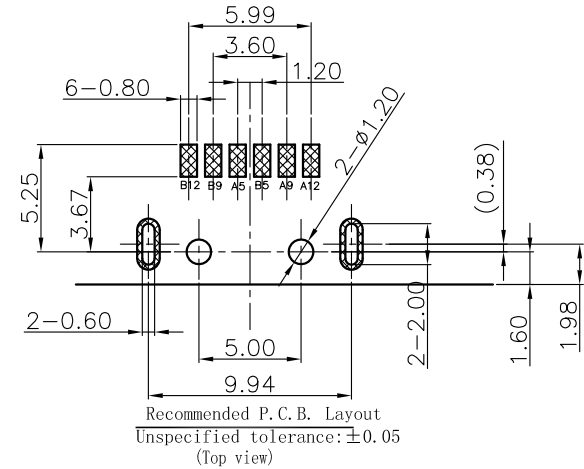
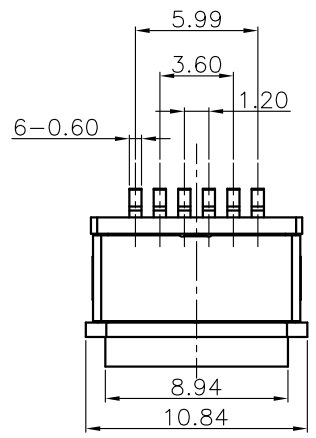
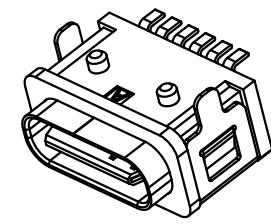
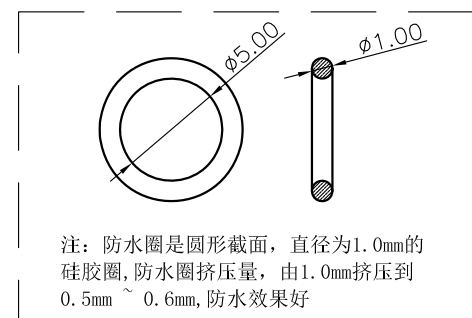
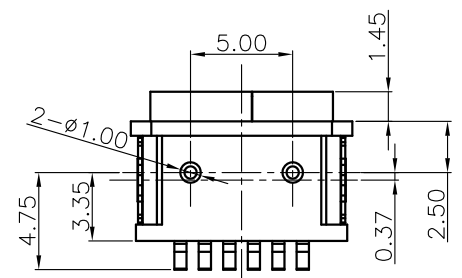

A5	CC1	B12	GND
A9	VBUS	B9	VBUS
A12	GND	B5	CC2
PIN	SIGNAL NAME	PIN	SIGNAL NAME

5	Shell2	1	SUS301 Ni Plating T=0.20mm	Ni:40~120u";
4	Shell1	1	SUS301 Ni Plating T=0.25mm	Ni:40~120u";
3	Housing2	1	PA10T(G.F30%)	
2	Contact	5	Phosphor bronze C5210R-EH Au/Ni Plating T=0.20mm	Ni:40~160u"; Au:CONTACT AREA:1u", OTHER AREA:G/F
1	Housing	1	PA10T (G.F30%)	
ITEM	PART NAME	Q' TY	FINISH	NOTE

TOLERANCE UNLESS OTHERWISE SPECIFIED		FLW 深圳市华联威电子科技有限公司			
.XXX ±0.10 .XX ±0.20 .X ±0.30		.X' ±3' .XX' ±2'		HUA LIAN WEI TECHNOLOGY ELECTRONICS CO;LTD.	
APPROVED		PART NAME:	TYPE C 6P SMT		
CHECKED		PART No:	U573-061B-G61018	C	
DRAWN		PROJECTION:	UNIT:	SCALE:	SHEET:
DATE			mm	1:1	10F1
					REV. A