

REV.	ECN.NO.	APPD.
A	/	/

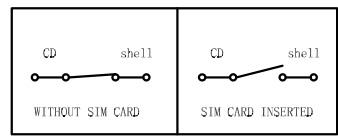
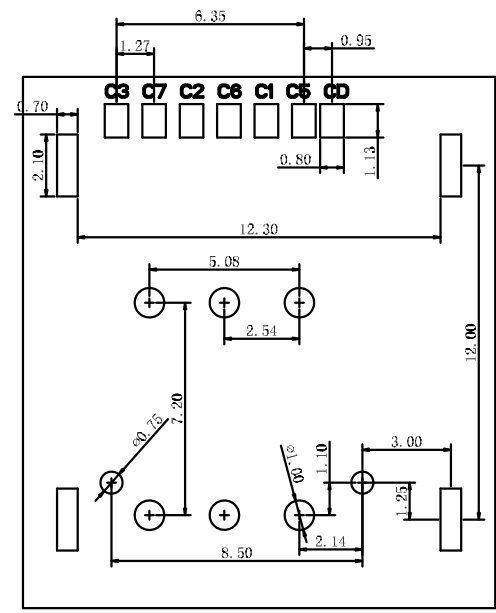
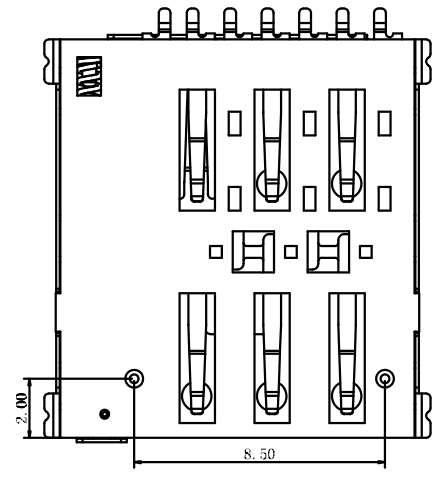
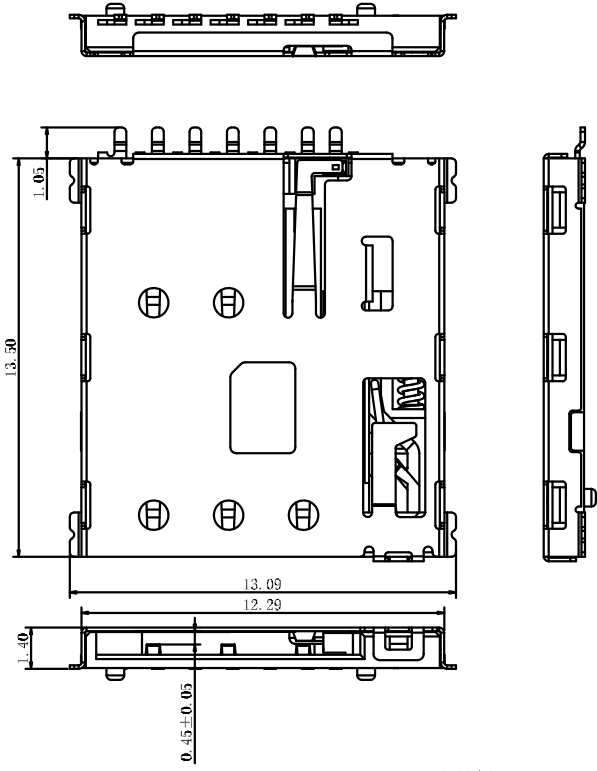

***Electrical Characteristics:**
 Contact Current Rating:0.5 Amperes.
 Dielectric Withstanding Voltage:AC500V r.m.s.
 Insulation Resistance:1000 MΩ Minimum.
 Contact Resistance:100 mΩ Maximum.

***Environmental:**
 Operating Temperature:-25°C~+90°C.

***Environmental:**
 Mating Cycles:5000~10,000 Insertions.

***Mechanical Characteristics:**
 Card Push Insertion/Out Force:1.4kgf. MAX
 Contact Separation Force:0.20kgf Minimum.

***Material:**
 Insulator:HI-Temp Plastic UL 94V-0 Rated.
 Contact:Copper Alloy(t=0.15mm).
 Shell:Stainless Steel(t=0.20mm).
 Spring:SWP.

SIM pin Assignment	
PIN#	Name
C1	VCC
C2	RST
C3	CLK
C5	GND
C6	VPP
C7	I/O

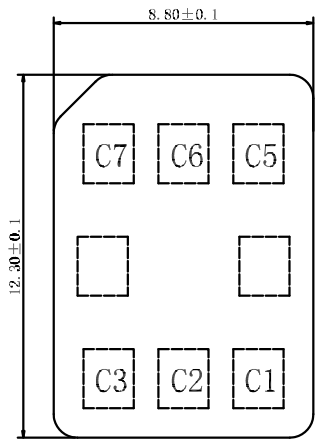

SD5209-14B-G68

G: 镀半金G/Fu
 6: LCP黑色

TOLERANCE UNLESS OTHERWISE SPECIFIED		FLW 深圳市华联威电子科技有限公司 HUA LIAN WEI TECHNOLOGY ELECTRONICS CO;LTD.				
.XXX ±0.10	.XX ±0.20	.X ±0.30	.X' ±3'			
			PART NAME:		SD NONO SIM 7PIN卡座带弹	
APPROVED			PART No:		SD5209-14B-G68	
CHECKED		yangguifeng		PROJECTION:		C
DRAWN		2021.11.15		UNIT:	SCALE:	SHEET:
DATE		2021.11.15		mm	1:1	10F1
				REV.	A	