

REV.	ECN.NO.	APPD.
A	/	chenyiting

NOTES:

1.MATERIAL:

- 1.1 Housing:thermoplastic plastics
- 1.2 terminals:Copper Alloy  
Gold plated in contact area:  
Tin plated in termination  
Nickel Plated overall
- 1.3 Shell:Steel&Copper Alloy  
Nickel/Au Plated overall

2.characteristics:

- 2.1 Rating Voltage : 30V AC.
  - 2.2 Rating Current:  
5A for Vbus PIN;1.25A for Vconn PIN
  - 2.3 Contact Resistance:40 mΩ MAX.
  - 2.4 Insulation Resistance:100 MΩ MIN.
  - 2.5 Withstanding Voltage:AC 100V
  - 2.6 Mating force: 5~20N MAX
  - 2.7 Extraction force:8~20N Min
  - 2.8 Life test:10000Cycles MIN.
  - 2.9 Temperature Range: -30℃~+80℃.
- The product must be compliance ROHS

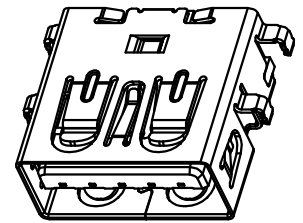
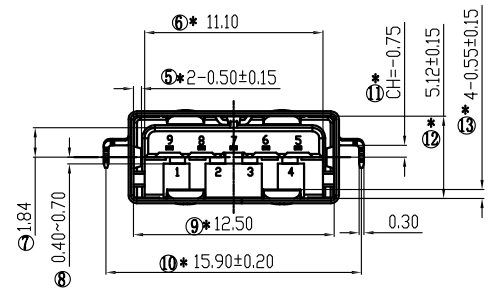
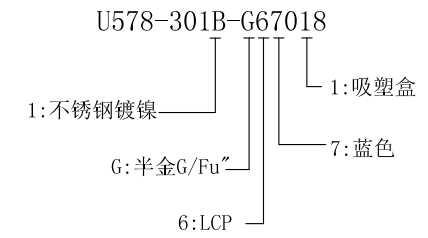
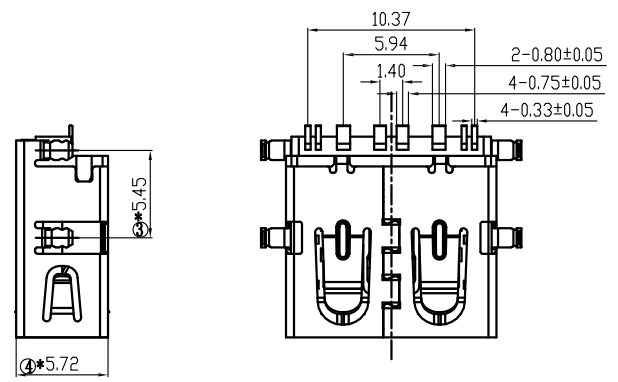
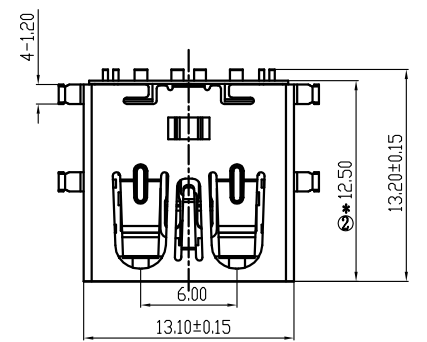
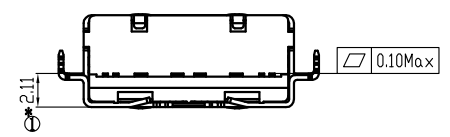
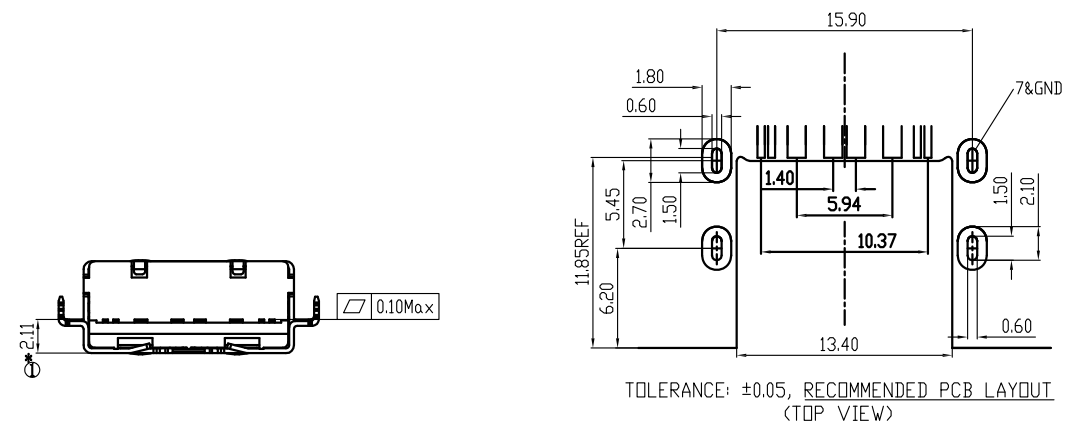

Pin NUMBER	SIGNAL NAME	TOLERANCE UNLESS OTHERWISE SPECIFIED	
1	VBUS	.XXX ±0.10	
2	D-	.XX ±0.20	.X ±3'
3	D+	.X ±0.30	.XX ±2'
4	GND	APPROVED	
5	StdA_SSRX-	CHECKED	
6	StdA_SSRX+	DRAWN	chenyiting
7	GND_DRAIN	DATE	2023.05.26
8	StdA_SSTX-		
9	StdA_SSTX+		
Shell	Shield		

**FLW 深圳市华联威电子科技有限公司**  
HUA LIAN WEI TECHNOLOGY ELECTRONICS CO.;LTD.

PART NAME:	USB TYPE C 3.1沉板2.11无卷边			
PART No:	U578-301B-G67018		C	
PROJECTION:	UNIT:	SCALE:	SHEET:	REV.
	mm	1:1	10F1	A