

# 承 认 书

Approval Sheet

客户 (Customer):

客户料号 (Cus .P/N):

华联威料号 (HLW P/N):R120-11100-G21017

品名规格 (PronameSpec):RJ11 6P4C 180度 无灯全塑

送样日期 (Delivery Date):2023/06/05

承认日期 (Acknowledge Date): 2023/06/05

Approved No:		客 户 Customer	
采 购 部 Purchasing Dept	品 质 部 QC Dept	工 程 部 Engineering Dept	确 认 Approved By
深 圳 市 华 联 威 电 子 科 技 有 限 公 司 SHEN ZHEN SHI HUA LIAN WEI ELECTRONICS TECHNOLOGY CO; LTD.			
业 务 部 Sales Dept	品 管 部 QC Dept	工 程 部 Engineering Dept	核 准 Checked By
欧阳小丽	欠必锋	陈依婷	唐竹君

地址:深圳市龙华区观澜街道桂香社区观澜桂花路 307 号

TEL: 0755-28888886 28888866

邮箱: hua@hlwconn.com

[Http://www.hlwconn.com](http://www.hlwconn.com)



# 目 录

## Contents

图纸.....	Page03
产品规格书.....	Page04-10
产品检测报告.....	Page11-12
尺寸测试报告.....	Page13
电镀报告.....	Page14
盐雾报告.....	Page15
材质证明.....	Page16-17
SGS.....	Page18-51

REV.	ECN.NO.	APPD.
A	XXXXXXXXXX	chenyiting

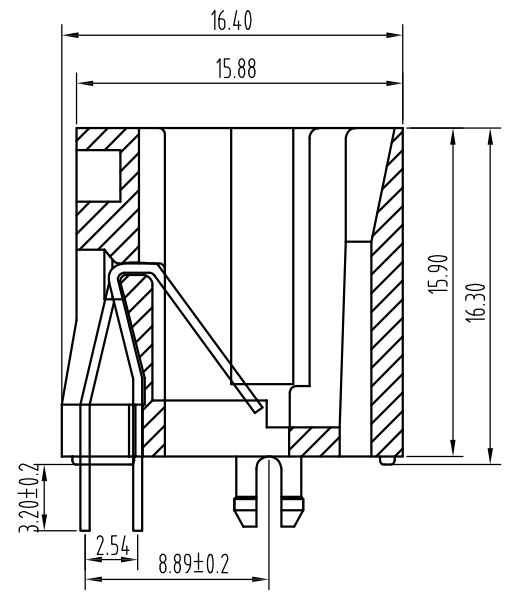
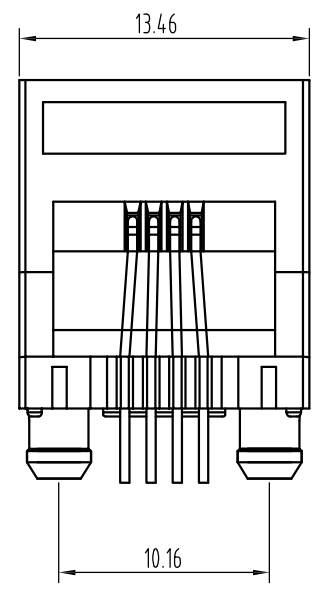

- NOTES:
- MATERIAL:
    - Housing:thermoplastic plastics
    - terminals:Copper Alloy  
Gold plated in contact area:  
OR Gold Plated overall
    - Shell:Steel&Copper Alloy  
Nickel/Tin Plated overall
  - ELECTRICAL CHARACTERISTICS:
    - Rating Current :1.5 Ampere
    - Rating Voltage :125 V Max
    - Contact Resistance:50 Milli ohms
    - Insulation Resistance:500 Mega ohms Min.
  - MECHANICAL CHARACTERISTICS:
    - Connector Mating force: 2.27kgf MAX
    - Durability:750Cycles.
  - ENVIRONMENT CHARACTERISTICS:
    - Operating temperature:-40℃ to +85℃
    - Storage temperature:-10℃ to +40℃

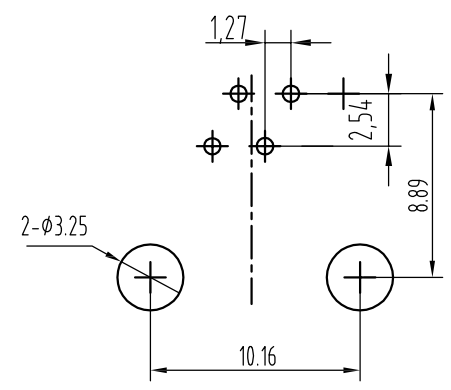
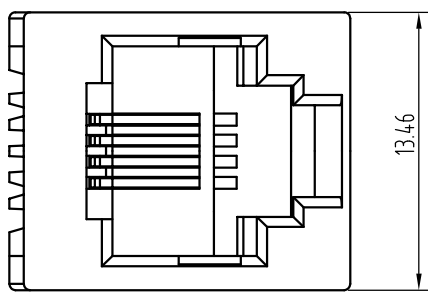

PC Board Layout  
Component Side Shown

R120-11100-G21017

G:半金G/Fu”  
1:吸塑盒  
1:黑色  
2:PBT

TOLERANCE UNLESS OTHERWISE SPECIFIED		<b>FLW</b> 深圳市华联威电子科技有限公司				
.XXX ±0.10 .XX ±0.20 .X ±0.30		HUA LIAN WEI TECHNOLOGY ELECTRONICS CO;LTD.				
APPROVED		PART NAME:	RJ11 6P4C 180度 无灯全塑			
CHECKED		PART No:	R120-11100-G21017	C		
DRAWN	chenyiting	PROJECTION:	UNIT:	SCALE	SHEET	REV.
DATE	2023.06.05		mm	1:1	10F1	A

### RJ45系列产品SPEC

版本版次: C

制定日期 20200707

适用范围 通用

## 1. Scope (范围)

## 1.1 Contents(内容)

This specification covers the performance, tests and quality requirements for the Electronics RJ45 Connector.  
(此份产品规格适用于RJ45连接器的产品功能, 测试方法及质量要求)

## 2. Requirements (要求):

## 2.1 Rating(额定条件)

A. Voltage rating(额定电压):125V AC

B. Current rating(额定电流):0.5A

C. Operation Temperature Range(操作温度范围):-40°C to +85°C

## 3. Test Condition(测试条件):

3.1 Temperature range(温度范围):-15°C to +35°C

3.2 Humidity range (湿度范围):25% to 85%

## 4. Test Methods and Requirements:(测试方法及要求)

## 4.1 Examination of product (产品外观)

4.1.1	Examination of Product 产品外观	(EIA-364-18B) Visual 目视	No peeling off the plating deformation of the base or damage. 不得有电镀层剥落, 塑料变形或破损
-------	--------------------------------	-------------------------------	--

## 4.2. Electrical Performance(电气性能)

4.2.1	Contact Resistance 接触阻抗	EIA-364-23C Subject mated contacts assembled housing to 20mV maximum 100Ma. Measured from plug side to PCB side.  组装好的端子施以最大电压20mV最大电流100mA从端口处到PCB端测试。	40mΩ Max (Initial) 50 mΩ Max(Final)  初始值最大40mΩ. 最终值最大50 mΩ.
4.2.2	Dielectric Withstanding Voltage (耐电压)	(EIA-364-20C) Mated connectors with 1000±5% VAC for 1 minute 0.5 mA between adjacent contacts or ground. 对组装好的独立端子或接地物之间施加交流1000VAC 0.5mA 电流1 分钟。	One minute hold with no breakdown or flashover. 不能有如跳电、击穿、破裂损坏。
4.2.3	Insulation Resistance 绝缘阻抗	(EIA-364-21C) Mated connectors with 500±10%VDC between adjacent contacts or ground. 对组装好的独立端子或接地物之间施以500±10%VDC的电压测试	500MΩ min (unmated)  没有配对需大于500 MΩ

## 4.3 Mechanical Performance(机械性能)

4.3.1	Insertion/Withdrawal Force 插入力/拔出力	(EIA-364-13) Insertion and withdrawal speed: 25mm/minute. 插入和拔出的速度为25mm/分	Maximum insertion force 22N 插入力不超过30N(3.0/kg) Withdrawal force 22N max 拔出力不超过30N(3.0/kg)
4.3.2	Durability 寿命测试	(EIA-364-09) Operation Speed:10 To 20cycle/min. Durability cycles:750cycles 测试速度：每分钟10到20个循环，测试次数：750次循环最少	Meet visual requirements,show no physical damage,and meet requirements of additional tests as specified in the product qualification  测试后满足外观要求，无变形损伤.
4.3.3	Vibration 振动	(EIA-364-28条件3) Amplitude:1.52mm P-P or 147m/s <sup>2</sup> {15G} Sweep time: 50-2000-50Hz in 20 minutes. Duration: 12 times in each (total of 36 times) X, Y, Z, axes. Electrical load DC 100mA current shall be flowed during the test.(ANSI/EIA-364-28 Condition III) 在直流100毫安通电状态下测试，在X,Y,Z垂直3方向上，频率50-2000-50赫兹（加速度往复20分钟），全振幅1.52mm P-P或147 m/s <sup>2</sup> {15G}，每轴12回计36回	Appearance: No damage 外观：无损坏  Discontinuity: 1μ sec Max. 间断性：不超过1微秒
4.3.4	Physical shock 冲击性	(EIA-364-27条件A) Pulse width: 11msec Waveform: Half-sine 490m/s <sup>2</sup> (50G) 3 strokes in each X, Y, Z axes. (ANSI/EIA-364-27 condition A) 周期：11msec 冲击波形：正弦半波490m/s <sup>2</sup> (50G) 3循环在X, Y, Z 轴	Appearance: No damage 外观：无损坏  Discontinuity: 1μ sec Max. 间断性：不超过1微秒
4.4 Environmental Performance			
4.4.1	Thermal shock test 冷热冲击	EIA-364-32C条件1) 10 cycles of: a)-55±3℃ for 30 minutes b) +85±3℃ for 30 minutes 10个循环， a)-55±3℃ 30 分钟 b) +85±3℃ 30 分钟	Appearance: No Damage. 外观：没有损坏 Contact Resistance 接触阻抗 Contact: Change from initial Value 30mΩ Max Shell Part: Change from initial Value 50mΩ Max 端子：从初始值开始变化量小于30mΩ 外壳：从初始值开始变化量小于50mΩ

4.4..2	Solder ability 焊锡性	<p>(EIA-364-52)</p> <p>To be sipped in the solder bath 260±5°C Coverage for 3 seconds. 将焊锡脚浸在260±5°C的锡炉中&lt;3秒</p>	The inspected area of each lead must have 95% solder coverage minimum
4.4..3	Humidity 恒温恒湿	<p>(EIA-364-31B)</p> <p>(A) Mate connectors together and perform the test as follows 配对的连接器测试条件 Temperature: +25°C to +85°C(温度: +25°C到+85°C) Relative Humidity: 80% to 90%(相对湿度: 80%到90%) Duration:4 cycles(96 hours) (持续时间: 4个循环共96小时) Upon completion of the test, specimens shall be conditioned ambient room conditions for 24 hours, after which the specified measurements shall be performed. 试验完成后, 样品放置于室温条件中24小时后再进行测试</p>	Appearance: No Damage 外观, 没有损坏
		<p>(EIA-364-31B)</p> <p>(B) Unmated each connector and perform the test as follows. 没有配对的连接器测试条件 Temperature: +25°C to +85°C(温度: +25°C到+85°C) Relative Humidity: 80% to 90%(相对湿度: 80%到90%) Duration:4 cycles(96 hours) (持续时间: 4个循环共96小时) Upon completion of the test, specimens shall be conditioned ambient room conditions for 24 hours, after which the specified measurements shall be performed. 试验完成后, 样品放置于室温条件中24小时后再进行测试</p>	Appearance: No Damage 外观, 没有损坏  Conform to item of dielectric withstanding Voltage and Insulation Resistance. 符合耐电压及绝缘阻抗要求

4.4..4	Salt Spray 盐水喷雾	EIA-364-26B) Tested as below: Temperature:(35±2) °C Humidity:(95-98)%(R.H.) PH:6.5-7.2 It shall be subjected to stand ard atmospheric condition 1hours after removing the salt deposits. It should meet the contact resistance.object non-contact area: Temperature: (35±2) °C Salt-solution(5±1)% Duration time:12hours 测试条件如下: 温度:(35±2) °C 湿度:(95-98)%(R.H.) PH值:6.5-7.2 物体在移出盐水槽后应置于标准大气条件中一个小时后再进行测量动作: 盐水密度: (5±1) % 持续时间: 12小时	No detrimental corrosion( Terminal solder tail unrequested) 产品无氧化, 锈蚀 (端子焊脚镀锡处不作要求)
4.4..5	Cold resistance (Unmated) 冷阻抗	(EIA-364-17B) Unmated connectors and expose to -40±3°C for 96 hours. Upon completion of the exposure period, the test specimens shall be conditioned at ambient room conditions for 1 to 2 hours, after which the specified measurements shall be performed. 没配对的连接器放置于-40±3°C温度中96小时, 当完成实验后, 样品放置一般环境中1到2小时后, 在进行测试	Appearance: No Damage. 外观: 没有损坏
4.4..6	Heat resistance (Unmated) 热阻抗	(EIA-364-17B) Mated connectors and expose to 85±2°C for 96hours. Upon completion of the exposure period, the test specimens shall be conditioned at ambient room conditions for 1 to 2 hours, after which the specified measurements shall be performed. 配对的连接器放置于85±2°C温度中96小时, 当完成实验后, 样品放置一般环境中1到2小时后, 在进行测试	Appearance: No Damage. 外观: 没有损坏

4.4..7	Thermal Aging 高温老化	<p>(EIA-364-31B, Condition 4, Method A) Unmated connectors and expose to <math>+105\pm 2^{\circ}\text{C}</math> for 96 hours. Upon completion of the exposure period, the test specimens shall be conditioned at ambient room conditions for 1 to 2 hours, after which the specified measurements shall be performed.</p> <p>没配对的连接器放置于<math>+105\pm 2^{\circ}\text{C}</math>温度中96小时, 当完成实验后, 样品放置一般环境中1到2小时后, 在进行测试</p>	Appearance: No Damage. 外观: 没有损坏
4.4.8	Resistance to Soldering Heat	<p>for wave soldering : mil-std-202f,method 210 A,test condition B 波峰焊: mil-std-202f, method 210 A, 试验条件B Pre-heat : <math>80^{\circ}\text{C}</math>, 60 Seconds 预热:<math>80^{\circ}\text{C}</math>, 60秒 Temperature : <math>260 \pm 5^{\circ}\text{C}</math> 温度:<math>260\pm 5^{\circ}\text{C}</math> Immersion duration : <math>10 \pm 1</math> sec. 浸泡时间:<math>10\pm 1</math>秒。</p> <p>for manual soldering :手动焊接: mil-std-202f,method 210 A,test condition A Pre-heat : No 预热:没有 Temperature : <math>350 \pm 10^{\circ}\text{C}</math> 温度:<math>350\pm 10^{\circ}\text{C}</math> Immersion duration :<math>3.5\pm 0.5</math> sec. 浸泡时间:<math>3.5\pm 0.5</math>秒</p>	No physical damage shall occur. 不可有损坏



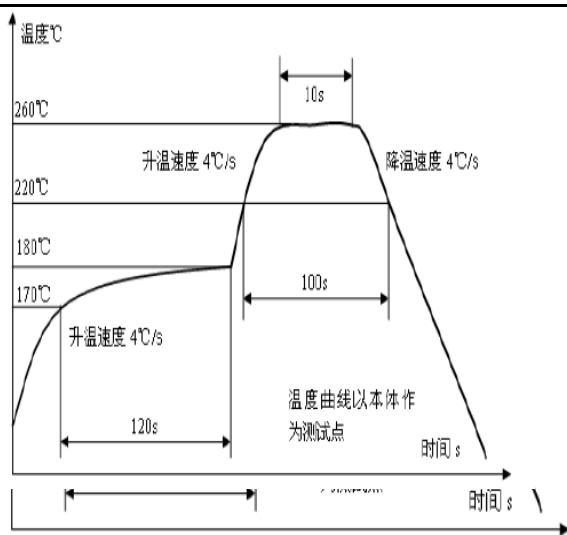

Note 1: Shall meet visual requirements, show no physical damage, and meet requirement of additional tests as specified in the test sequence in Figures 2

说明1: 测试要求不能有物理损坏, 测试依据表格二的顺序进行

3.Product Qualification And Requalification Test:产品测试顺序表 Figure 2

Test or Examination	Test Group													
	A	B	C	D	E	F	G	H	I	J	K	L	M	N
Test Sequence														
4.1.1.Examination of Product 产品外观	1,9	1,3	1,5	1	1,5	1,5	1,5	1,3	1,5	1,5	1,5	1,5	1,5	1
4.2.1.Contact Resistance 接触阻抗	2,8		2,4		2,4	2,4	2,4		2,4	2,4	2,4	2,4	2,4	
4.2.2.Dielectric Withstanding Voltage	3,7													
4.2.3.Insulation Resistance 绝缘阻抗	4,6													
4.3.1.Insertion/Withdrawal force 插拔力		2												
4.3.2.Durability 寿命测试			3											
4.3.3.Vibration 振动性					3									
4.3.4.Physical shock 冲击性						3								
4.4.1.Thermal shock test 冷热冲击							3							
4.4.2.Solderability 焊锡性								2						
4.4.3.Humidity 恒温恒湿	5								3					

4.4.4.Salt Spray 盐水喷雾										3				
4.4.5.Cold resistance 冷阻抗											3			
4.4.6.Heat resistance 热阻抗												3		
4.4.7.Thermal Aging 高温老化													3	
4.4.8.IR-reflow 回流焊测试														2
NO. of Test samples(Min.) 测试样	5	5	5	5	5	5	5	5	5	5	5	5	5	5

NOTE 2: (a) Numbers indicate sequence in which tests are performed.

(b) Discontinuities shall not take place in this test group, during tests.

说明 2: (a)测试依照矩阵要求数量进行。

(b)在测试中，群组测试不能间断

核准：唐竹君

制作人：魏红

## 測試報告

## TEST REPORT

產品名稱 Part Name	RJ11 6P 4C 180度 无 灯全塑	測試日期 Date of Testing	2023.06.03- 2023.06.05	報告編號 Report NO.	MD202300605-01
產品型號 Part Name	R120-11100-G21017	樣品數量 Quantity	5PCS	測試環境 Measuring Environment	濕度 Temp:18~21°C 相對濕度RH:49~57

## 一.電性測試 ELECTRICAL TEST

序號 NO.	測試項目 Testing Item	測試條件 Testing Conditions	測試設備 Testing Equipment	規格 SPEC	測試記錄 Testing Result					判定 Judge	
					1	2	3	4	5	Pass	Fail
1	Contact resistance	Test current:100mA max	DIGITAL MICRO- OHMMETER	50mΩ Max	20.31 mΩ	21.12 mΩ	19.63 mΩ	18.55 mΩ	22.53 mΩ	P	
2	Insulation resistance	Test voltage:500VDC Operation stated:1min	ULTRA HIGH RESISTANCE METER	500MΩ Min	Pass	Pass	Pass	Pass	Pass	P	
3	Dielectric withstand voltage	Test voltage:1000VAC Cut-off current:0.5mA Operation stated:1 min	BREAKDOWN TESTER	No discharge or flashover occur	Pass	Pass	Pass	Pass	Pass	P	

## 二.機械特性測試 MECHANICAL TEST

序號 NO.	測試項目 Testing Item	測試條件 Testing Conditions	測試設備 Testing Equipment	規格 SPEC	測試記錄 Testing Result					判定 Judge	
					1	2	3	4	5	Pass	Fail
1	Durability test	Rate:200cycles/hour Total: 750 cycles	LIFE TESTER FOR CONNECTOR	No physical damage	Pass	Pass	Pass	Pass	Pass	P	
2	Mating Force	29.4Newtons maximum at a maximum rare of 7.5mm(0.39") per minute	Insertion force testing machine	3.0kgf Max	Pass	Pass	Pass	Pass	Pass	P	

## 三.環境特性測試 ENVIRONMENTAL TEST

序號 NO.	測試項目 Testing Item	測試條件 Testing Conditions	測試設備 Testing Equipment	規格 SPEC	測試記錄Testing Result					判定Judge	
					1	2	3	4	5	Pass	Fail
1	Humidity-Temperature cycle	Temperature: 40±2°C Humidity: 90~95% Duration:168H	PROGRAM CONTROLLED TEMP. & HUMIDTY CHAMBER	No physical damage	Pass	Pass	Pass	Pass	Pass	P	
2	Heat test	Temperature: 70±2°C Duration:168H	OVEN	No physical damage	Pass	Pass	Pass	Pass	Pass	P	
3	Cold test	Temperature: -25±3°C Duration:168H	PROGRAM CONTROLLED TEMP. & HUMIDTY CHAMBER	No physical damage	Pass	Pass	Pass	Pass	Pass	P	
4	Temperature cycling test	Temperature: -55~85°C Duration:10 cycle	PROGRAM CONTROLLED TEMP. & HUMIDTY CHAMBER	No physical damage	Pass	Pass	Pass	Pass	Pass	P	

#### 四.物理測試 PHYSICAL TEST

序號 NO.	測試項目 Testing Item	測試條件 Testing Conditions	測試設備 Testing Equipment	規格 SPEC	測試記錄Testing Result					判定Judge	
					1	2	3	4	5	Pass	Fail
1	Salt spray test	Temperature: 35±2°C Concentration:5±1 % Duration:12H	SALT SPRAY TESTER	No Oxidation	Pass	Pass	Pass	Pass	Pass	P	
2	Resistance to soldering heat test	Temperature: 260°C Duration:3 sec	OVEN	No physical damage	Pass	Pass	Pass	Pass	Pass	P	
3	Solder ability test	Temperature: 260±5°C Duration:5±0.5 sec	CONTROLLED CONSTANT-TEMP SOLDER POT	Soldering area ≥95	Pass	Pass	Pass	Pass	Pass	P	
判定 Result		<input checked="" type="checkbox"/> 合格 (ACCEPT) <input type="checkbox"/> 不合格 (REJECT)									

核准(Approver): 欠必鋒

測試(Tester): 但芬

# 深圳市华联威电子科技有限公司

## 检验报告

首件检验 
 入库检验 
 出货检验 
 客退检验 
 退料检验 
 其他

2023年06月05日 版次:A1

料号	R120-11100-G21017	制令单号	/					送检单位	工程部	首件制作者	装配		
品名	RJ11 6P4C 180度 无灯全塑	客户代号	/					批 量	/	送检时间	/		
								数 量	5PCS	确认时间	/		
抽样标准		<input checked="" type="checkbox"/> 单次 <input type="checkbox"/> 双次					抽样数	AQL	CRI:0	MAJ:0.40	MIN:0.65		
MIL-STD-105E(II)		<input checked="" type="checkbox"/> 正常 <input type="checkbox"/> 加严 <input type="checkbox"/> 减量					( 5PCS )	ACC/REJ	0	/	/		
不良数: CRI ( / ) MAJ ( / ) MIN ( / )								不良率(%)		/			
NO.	检验项目	检测仪器	检 验 记 录					品管判定		CRI	MAJ	MIN	备注
	单位:MM/G		1	2	3	4	5	AC	RE				
	13.46±0.20	D	13.48	13.46	13.48	13.48	13.49	√					
	10.16±0.20	D	10.17	10.16	10.17	10.19	10.15	√					
	16.40±0.20	D	16.42	16.43	16.41	16.42	16.42	√					
	15.88±0.20	D	15.90	15.92	15.89	15.90	15.90	√					
	15.90±0.20	D	15.93	15.95	15.93	15.94	15.92	√					
	16.30±0.20	D	16.32	16.31	16.32	16.33	16.32	√					
	3.20±0.20	D	3.21	3.23	3.21	3.23	3.23	√					
	2.54±0.20	D	2.56	2.58	2.57	2.58	2.58	√					
	8.89±0.20	D	8.93	8.92	8.93	8.91	8.92	√					
	13.46±0.20	D	13.48	13.47	13.49	13.48	13.48	√					

检验依据: 《工程图纸》 《检验规范》 《承认书》 样品 其它

检测仪器:A游标卡尺 B千分尺 C厚薄仪 D投影镜 E放大镜 F显微镜 G锡炉 H插拔力器 I间位尺 J其它

品保判定:

核 准 APP	欠必锋	审 核 CHK	/	检 验 员 INSPBY	但芬
------------	-----	------------	---	-----------------	----

品名: RJ11 6P6C 180度 无灯全塑 (端子)	版次:A.0				
电镀规格:Ni30u", Sn100u", Au G/Fu"	日期:2023/03/04	页次:1/1			
厂商:同华					
测试设备:CMI X-射线膜厚测试仪					
1、底层电镀测试 (Ni)					
数据	测试标准	实测值	判定	测试日期	测试时间
1	30u"MIN	53.5u"	OK	2023/3/4	10:20:15
2	30u"MIN	52.3u"	OK	2023/3/4	10:20:17
3	30u"MIN	60.5u"	OK	2023/3/4	10:20:19
4	30u"MIN	63.4u"	OK	2023/3/4	10:20:21
2、表层电镀测试 (Sn)					
数据	测试标准	实测值	判定	测试日期	测试时间
1	100u"MIN	107.3u"	OK	2023/3/4	10:25:10
2	100u"MIN	104.7u"	OK	2023/3/4	10:25:12
3	100u"MIN	106.9u"	OK	2023/3/4	10:25:14
4	100u"MIN	103.4u"	OK	2023/3/4	10:25:16
3、表层电镀测试 (Au)					
数据	测试标准	实测值	判定	测试日期	测试时间
1	0.5u"MIN	0.65u"	OK	2023/3/4	10:30:32
2	0.5u"MIN	0.54u"	OK	2023/3/4	10:30:34
3	0.5u"MIN	0.56u"	OK	2023/3/4	10:30:36
4	0.5u"MIN	0.54u"	OK	2023/3/4	10:30:38

核准: 欠必锋

审核: 李娟

检验员: 但芬



# 深圳市华联威电子科技有限公司

## 盐水喷雾实验报告

试验方法	盐水喷雾腐蚀试验法	参考资料	MIL-STD-1345
METHOD	NEUTRL SALT SPRAY CORROSION TEST	REF	
客户		试验起始日期	2023年06月04日 20:00 时起
		DATE	2023年06月05日 08:00 时止
样品名称	RJ11 6P6C 180度 无灯全塑	试验数量	5PCS
P/N	R120-11100-G21017	QTY	
试验条件 (TEST CONDDITION)			
1、盐水溶解 (SALT SOLUTION: 浓度 $50\pm 10\text{g/L}$ , PH值6.5-7.2).			
2、试验室温度 (TEMP. IT THE SPRAY DHAMBR): $35\pm 1^\circ\text{C}$ .			
3、盐水桶温度 (TEMP. OF SALE SOL' N TANK): $35\pm 1^\circ\text{C}$ .			
4、压力桶温度 (TEMP. OF SAR SUPPLIERY): $47\pm 1^\circ\text{C}$ .			
5、试验室相对湿度 (R. H IN THE CHAMBER ) 85%.			
6、压缩空气压力 (COMPRESSED AIR PRESSURE): $1.00\pm 0.01\text{Kg/cm}^2$ .			
7、样品放置位置 (SPECIMEN SUPPORTED ANGLE ): 尼龙绳吊挂 $70^\circ -90^\circ$ .			
8、喷雾收集量 (COLLECT RATE OF SALT SOL' N) $1-2\text{mL}/(8\text{ cm}^2\text{hr})$ .			
9、盐雾测试时间: 12小时 (H)			
判定方法 (ADFUSGD METHOD )			
试验后以20倍放大镜观察、无蓝、绿色腐蚀物之现象 (不包含折弯处), 即判定合格. (Inspext the ecimen at 20 xmagnification no blue or green corrosion products are acceptable)			
样品序号	试验后现象	判定	
	PHENOMENON AFTER TEST	COMMENT	
1	无蓝、绿色腐蚀物之现象	OK	
2	无蓝、绿色腐蚀物之现象	OK	
3	无蓝、绿色腐蚀物之现象	OK	
4	无蓝、绿色腐蚀物之现象	OK	
5	无蓝、绿色腐蚀物之现象	OK	

核准: 欠必锋

审核: 李娟

试验员: 但芬

# 材 质 证 明

兹有我司邦奇塑料科技有限公司为贵司所提供的产品不防火增加级原料 PBT 不防火加纤 20%黑色，由以下物质组成：

物品名称：PBT 不防火加纤黑色 20%

组成物质：PBT 环保树脂	60-70%
玻纤	20-25%
增韧剂	7-9%
润滑剂	0.1%
抗氧化剂	0.1%
偶联剂	0.5%
其它	0.3%
黑色母	1-2%

建议成型：

1. 烘干温度 120-140℃
2. 烘干时间 2-4 小时
3. 成型温度 240-260℃

特此证明！

东莞市邦奇塑料科技有限公司





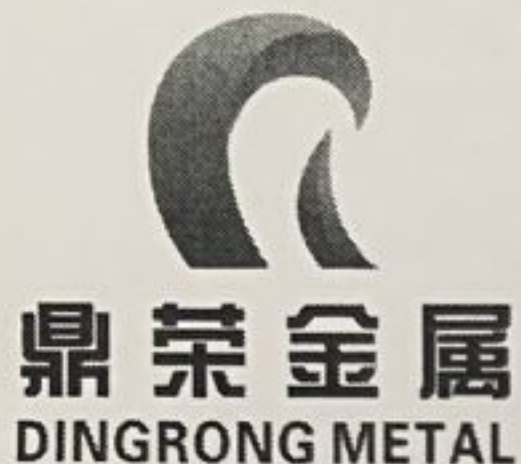

# 东莞市鼎荣金属材料有限公司

DongGuanDingRongMetalsMaterialCo., Ltd

## 产品质量证明书

CERTIFICATE OF QUALITY

电话: 0769-85220060

传真: 0769-85220061

网址: www.dingrongjinshu.com

邮箱: dingrong1978@163.com

地址: 东莞市虎门镇雅瑶怀雅大道73号

客户名称 Customer	华联威			产品名称 product name	C5191
合同编号 Contract No	P0202111130001			执行标准 Carried Standard	JISH3110:2012
尺寸公差 (mm) Size Tolerance	厚度 (Thickness)	0.3	+0-0.015	生产日期 Dete	2021-11-16
	宽度 (Width)	41/39	+0-0.08		

## 性能与含量

序号 NO.	批号 Lot No.	状态 Temper	卷数 Volume	规格及重量 Material Description			化学成份 Chemioal compositon							物理性能 Physical Property		
				厚度 Thick	宽度 Width	重量 Weight	铜 Cu%	锡 Sn%	磷 P%	锌 Zn%	铅 Pb%	铁 Fe%	镍 Ni%	抗拉强度 (N/mm <sup>2</sup> ) Tensile Strength	延伸率 (%) Elongation	硬度值 (HV) Hardness
1	F2555	EH	1	0.3	41	102.1	余量	5.0-7.0	0.03-0.35	≤0.20	≤0.020	≤0.10	-	635-720	≥5%	210-230
2	F2555	EH	5	0.3	39	489.7	余量	5.740	0.180	0.033	0.004	0.009	0.038	702	6	218
				合计 (Total)			591.8			质量检验章: Quality inspection stamp						

一、到货后请立即验收并放于室内干燥处。

二、本材质证明书希妥善保管, 如对我司产品品质与异议, 持材质证明在一个月內与我司联系, 我司将竭诚为您服务。

三、如有质量问题, 请注明产品牌号、规格、状态、批号、收获日期等信息, 以便于追溯与改进。

四、本材质证明涂改、复印无效。

品质主管: 范善益

审核人: 梅旭峰

