

REV.	ECN.NO.	APPD.
A	XXXXXXXXXX	yangguifeng

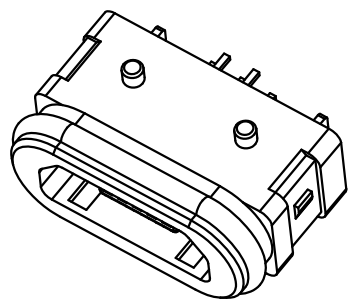

3D VIEW

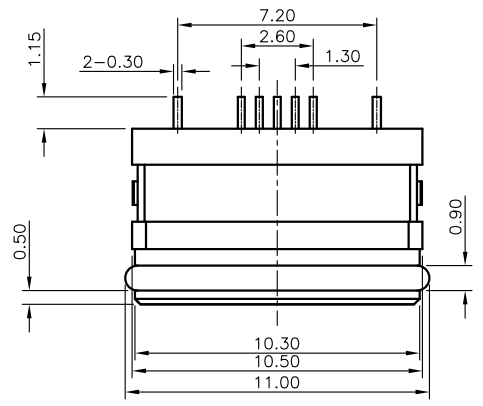
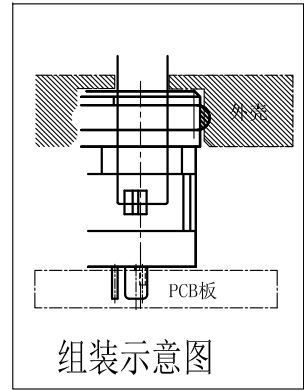

组装示意图

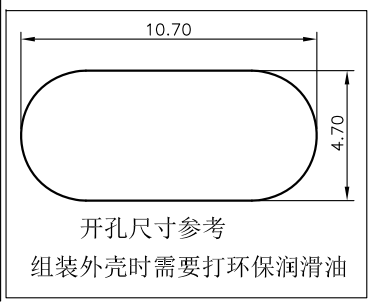

开孔尺寸参考  
组装外壳时需要打环保润滑油

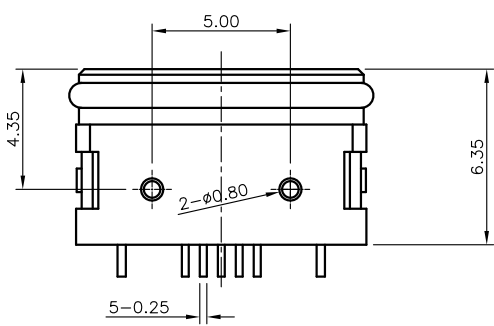
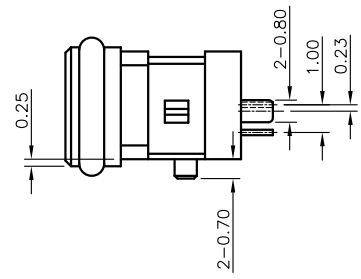
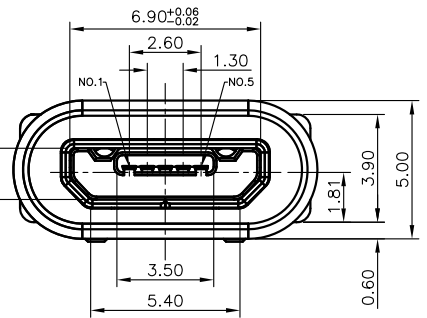

- NOTES:
- MATERIAL:
    - Housing: thermoplastic plastics,
    - terminals: Copper Alloy  
Gold plated overall
    - Shell: Steel & Copper Alloy  
Nickel/Tin Plated overall
  - ELECTRICAL CHARACTERISTICS:
    - Rating Current :1.5 Ampere
    - Rating Voltage :30 V Max
    - Contact Resistance:50 Milli ohms
    - Insulation Resistance:100 Mega ohms Min.
  - MECHANICAL CHARACTERISTICS:
    - Connector Mating force: 35N MAX
    - Connector Unmating force:7N min
  - ENVIRONMENT CHARACTERISTICS:
    - Operating temperature:-0°C to +50°C
    - Storage temperature:-20°C to +60°C

U442-C24X-XXX0X8  
 B: 不锈钢镀镍  
 G: 半金G/Fu  
 3: 载带  
 5: PA9T  
 1: 黑色

NO.	DESCRIPTION	QTY	MATERIAL	REMARK
⑤	Oval ring	1	磁橡胶	Black
④	Inner shell	1	SUS304	Nickel plated
③	Terminal	5	C5191, 0.15t	Gold Plated On Contact Area.
②	Outer shell	1	PA9T	Black
①	Body	1	LCP	Black

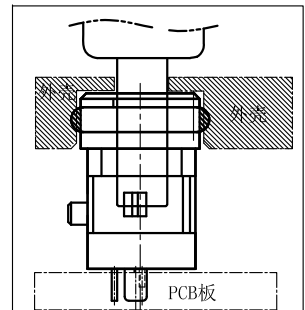

组装示意图

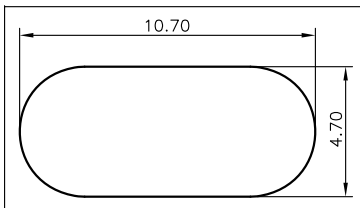

开孔尺寸参考  
组装外壳时需要打环保润滑油

TOLERANCE UNLESS OTHERWISE SPECIFIED		FLW 深圳市华联威电子科技有限公司 HUA LIAN WEI TECHNOLOGY ELECTRONICS CO;LTD.				
.XXX ±0.10	.XX ±0.20	.X ±0.30	.X' ±3'	.XX' ±2'		
APPROVED		PART NAME:	MICRO 5P 短体6.35无脚SMT有柱0.8			
CHECKED		PART No:	U442-C24B-G51038		C	
DRAWN	yangguifeng	PROJECTION:	UNIT:	SCALE	SHEET	REV.
DATE	2021.12.01		mm	1:1	1 OF 1	A