

承 认 书

Approval Sheet

客户 (Customer): /

客户料号 (Cus .P/N): /

华联威料号 (HLW P/N): DP21-0815-G61038

品名规格 (PronameSpec) DP 卧式贴片

送样日期 (Delivery Date): 2023/01/29

承认日期 (Acknowledge Date): 2023/1/29

Approved No:		客 户 Customer	
采 购 部 Purchasing Dept	品 质 部 QC Dept	工 程 部 Engineering Dept	确 认 Approved By
深 圳 市 华 联 威 电 子 科 技 有 限 公 司 SHEN ZHEN SHI HUA LIAN WEI ELECTRONICS TECHNOLOGY CO; LTD.			
业 务 部 Sales Dept	品 管 部 QC Dept	工 程 部 Engineering Dept	核 准 Checked By
万金菊	欠必锋	魏红	唐竹君

地址: 深圳市龙华区观澜街道桂香社区观澜桂花路 307 号

TEL: 0755-28888886 28888866

邮箱: hua@hlwconn.com

[Http://www.hlwconn.com](http://www.hlwconn.com)



目 录

Contents

图纸.....	Page03-04
产品规格书.....	Page05
产品检测报告.....	Page06-07
尺寸测试报告.....	Page08
电镀报告.....	Page09-10
盐雾报告.....	Page11
材质证明.....	Page12-13
SGS.....	Page14-51

REV.	ECN.NO.	APPD.
A	/	/
B	根据实物更改尺寸	TZJ

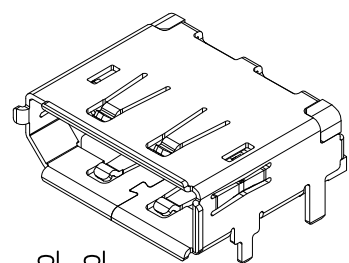
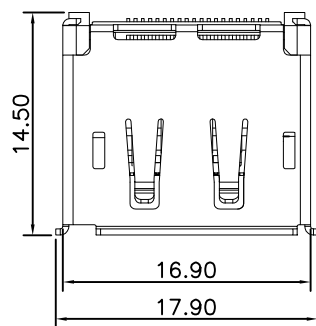

NOTES:

- SPECIFICATION:
 - CURRENT RATING: 0.5 A
 - CONTACT RESISTANCE: 30mΩ MAX.
 - DIELECTRIC WITHSTANDING VOLTAGE: 500VAC R.M.S FOR ONE MINUTE.
 - INSULATION RESISTANCE: 100MΩMINAT500VDC.
 - OPERATING TEMPERATURE: -25° TO +85°.
 - DURABILITY: 10000 CYCLES.
 - MATING FORCE: 4.5KG MAX.
 - UNMATING FORCE: 1.0KG MIN

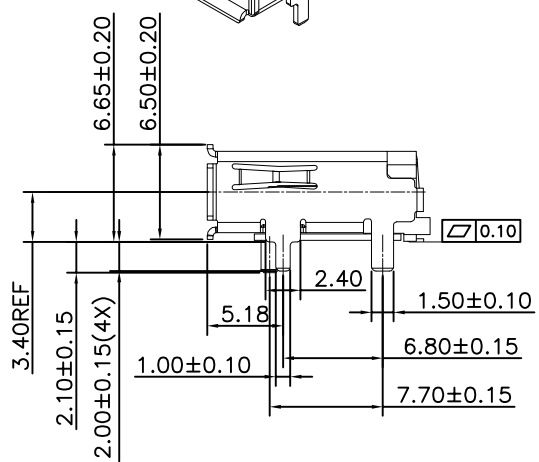
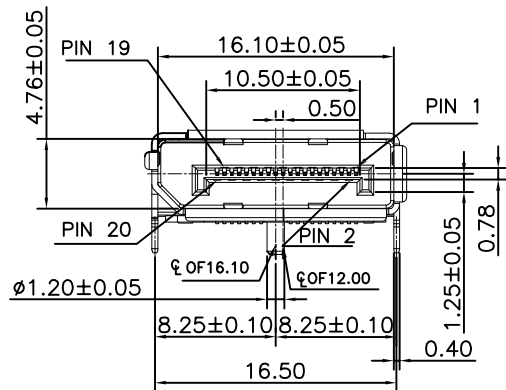

DP21-0815-G61038

- 5: 铜壳镀镍
- G: 半金G/Fu
- 6: LCP
- 3: 载带
- 1: 黑色

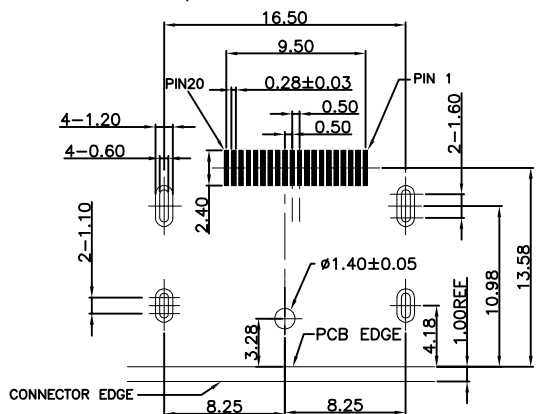
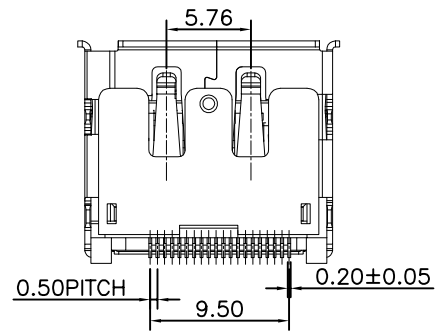

RECOMMENDED P.C.B LAYOUT(PCB THICKNESS: 1.6mm)
COMPONENT SIDE VIEW(TOLERANCE: ±0.05)

TOLERANCE UNLESS OTHERWISE SPECIFIED		FLW 深圳市华联威电子科技有限公司			
.XXX ±0.10		HUA LIAN WEI TECHNOLOGY ELECTRONICS CO;LTD.			
.XX ±0.20		.X' ±3'			
.X ±0.30		.XX' ±2'			
APPROVED		PART NAME:	DP 卧式贴片		
CHECKED		PART No:	DP21-0815-G61038	C	
DRAWN	weihong	PROJECTION:	UNIT:	SCALE:	SHEET:
DATE	2021.11.06		mm	1:1	10F1
					REV. B

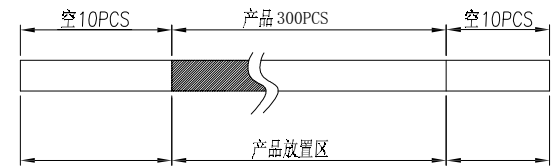
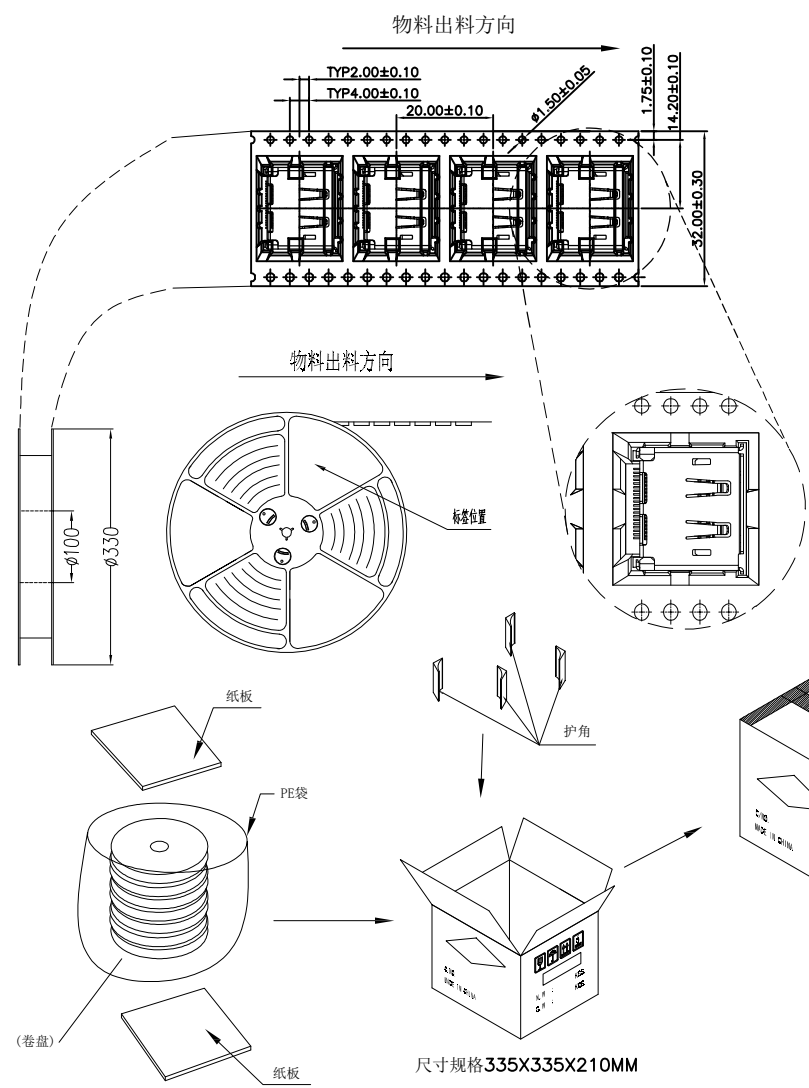

1. 将全检后的载带包装产品，每盘装300PCS产品，每箱装5盘，共装1500PCS产品。
2. 装入规格为335*335*210的纸箱中，然后用透明胶纸封箱。
3. 依据客户要求在外箱产品标签处贴上相应的标签。

TOLERANCE UNLESS OTHERWISE SPECIFIED
.XX ±0.15
.X ±0.30
X ±0.50
.X* ±3*

产品名称	DP 卧式贴片	
PART NAME:		
料号	DP21-0815-G61038	P
图号	B-2013	

REV:	DESCRIPTION	REV BY	APPROVED	DATE	MATL:	SEE SPECIFICATION	APPROVED
A					PROJECTION:	THIRD ANGLE PROJECTION	CHECKED
					UNIT:	SCALE	REV(NO)
A	新版发行	weihong		2022. 12. 07	mm	1:1	A
						SHEET	DRAWN
						1 OF 1	DATE

weihong	HWA 深圳市华联威电子科技有限公司
2022. 12. 07	
HUA LIAN WEI TECHNOLOGY ELECTRONICSCO;LTD.	

DP 系列產品SPEC

TEST ITEM		REQUIREMENT	PROCEDURE
1	Examination of Product	Meets requirements of product drawing. No physical damage.	Visual inspection.
2	Operating Temperature :	0°C ~+50°C	
3	Storage Temperature :	-25°C ~+85°C	
ELECTRICAL REQUIREMENT			
4	Rating Voltage	40V rms maximum	
5	Rating Current	1.5A mpheres max	
6	Contact Resistance	[30] m Ohm maximum	EIA 364-23 Subject mated contacts assembled in housing to 20mV Max open circuit at 100mA Max.
7	Dielectric withstanding Voltage	No creeping discharge or flashover shall occur.Current leakage: 2 mA MAX	EIA 364-20 [500]VAC for 1minute Test between adjacent circuits of unmated connector.
8	Insulation Resistance	[1000] M Ohm Min.	EIA 364-21 Impressed voltage 500 VDC.Test between adjacent circuits of unmated connector.
Mechanical Requirement			
9	Connector Mating Force	<u>44.1N Max.</u>	EIA 364-13 Operation Speed : [7.5+/-3] mm/min.Measure the force required to mate connector.
10	Connector Unmating Force	<u>10N Min.initial</u>	EIA 364-13 Operation Speed : [7.5+/-3] mm/min.Measure the force required to unmate connector.
11	Durability	See Note	EIA 364-09 Operation Speed: [200] cycle/Hour.Durability Cycles: 10000 Cycles
12	Solder ability	Wet solder coverage:95%Min	EIA 364-52 Solder Temperature : 260+/-5°C Duration : 5+/-0.5 sec,
Environmental Requirements			
13	Resistance to Wave Soldering Heat	No physical damage shall occur.	Test connector on PCB Pre-Heat : 150~200°C: 60 sec. max. ,Heat 235°C min for 10 Seconds max. Peak 260°C ±5 °C
備注		無客戶指定增加測試項目外，依照此標準進行產品可靠性評估。	

測試報告

TEST REPORT

產品名稱 Part Name	DP21-0815-G61038	測試日期 Date of Testing	2023.01.28- 2023.01.29	報告編號 Report NO.	MD20230129-02
產品型號 Part Name	DP 臥式贴片	樣品數量 Quantity	5PCS	測試環境 Measuring Environment	濕度 Temp:18~21°C 相對濕度RH:49%~57%

一.電性測試 ELECTRICAL TEST

序號 NO.	測試項目 Testing Item	測試條件 Testing Conditions	測試設備 Testing Equipment	規格 SPEC	測試記錄Testing Result					判定Judge	
					1	2	3	4	5	Pass	Fail
1	Contact resistance	Test current:100mA max	DIGITAL MICRO-OHMMETER	30 mΩ Max	26.17 mΩ	27.55 mΩ	25.47 mΩ	24.32 mΩ	27.83 mΩ	P	
2	Insulation resistance	Test voltage:500VDC Operation stated:1min	ULTRA HIGH RESISTANCE METER	100 MΩ Min	247 MΩ	285 MΩ	317 MΩ	355 MΩ	412 MΩ	P	
3	Dielectric withstand voltage	Test voltage:500VAC Cut-off current:0.5mA Operation stated:1 min	BREAKDOWN TESTER	No discharge or flashover occur	Pass	Pass	Pass	Pass	Pass	P	

二.機械特性測試 MECHANICAL TEST

序號 NO.	測試項目 Testing Item	測試條件 Testing Conditions	測試設備 Testing Equipment	規格 SPEC	測試記錄Testing Result					判定Judge	
					1	2	3	4	5	Pass	Fail
1	Durability test	Rate:100cycles/hour Total: 10000cycles	LIFE TESTER FOR CONNECTOR	No physical damage	Pass	Pass	Pass	Pass	Pass	P	
2	Mating Force	44.1 Newtons maximum at a maximum rare of 12.5mm(0.39") per minute	Insertion force testing machine	No physical damage	Pass	Pass	Pass	Pass	Pass	P	
3	Un-Mating Force	9.8 Newtons minimum at a maximum rare of 12.5mm(0.492") per minute	Insertion force testing machine	No physical damage	Pass	Pass	Pass	Pass	Pass	P	

三.環境特性測試 ENVIRONMENTAL TEST

序號 NO.	測試項目 Testing Item	測試條件 Testing Conditions	測試設備 Testing Equipment	規格 SPEC	測試記錄Testing Result					判定Judge	
					1	2	3	4	5	Pass	Fail
1	Humidity-Temperature cycle	Temperature: 40±2°C Humidity: 90~95 Duration:168H	PROGRAM CONTROLLED TEMP. & HUMIDTY CHAMBER	No physical damage	Pass	Pass	Pass	Pass	Pass	P	
2	Heat test	Temperature: 70±2°C Duration:168H	OVEN	No physical damage	Pass	Pass	Pass	Pass	Pass	P	

3	Cold test	Temperature: $-25 \pm 3^{\circ}\text{C}$ Duration:168H	PROGRAM CONTROLLED TEMP. & HUMIDTY CHAMBER	No physical damage	Pass	Pass	Pass	Pass	Pass	P	
4	Temperature cycling test	Temperature: $70 \sim 25^{\circ}\text{C}$ Duration:5 cycle	PROGRAM CONTROLLED TEMP. & HUMIDTY CHAMBER	No physical damage	Pass	Pass	Pass	Pass	Pass	P	

四.物理測試 PHYSICAL TEST

序號 NO.	測試項目 Testing Item	測試條件 Testing Conditions	測試設備 Testing Equipment	規格 SPEC	測試記錄 Testing Result					判定 Judge	
					1	2	3	4	5	Pass	Fail
1	Salt spray test	Temperature: $35 \pm 2^{\circ}\text{C}$ Concentration: $5 \pm 1\%$ Duration:24H	SALT SPRAY TESTER	No Oxidation	Pass	Pass	Pass	Pass	Pass	P	
2	Resistance to soldering heat test	Temperature: $260 \pm 5^{\circ}\text{C}$ Duration: 10 ± 1 sec	OVEN	No physical damage	Pass	Pass	Pass	Pass	Pass	P	
3	Solder ability test	Temperature: $260 \pm 5^{\circ}\text{C}$ Duration: 5 ± 0.5 sec	CONTROLLED CONSTANT-TEMP SOLDER POT	Soldering area $\geq 95\%$	Pass	Pass	Pass	Pass	Pass	P	
判定 Result		<input checked="" type="checkbox"/> 合格 (ACCEPT) <input type="checkbox"/> 不合格 (REJECT)									

核准(Approver): 欠必鋒

測試(Tester): 但芬

檢驗報告

首件檢驗 入庫檢驗 出貨檢驗 客退檢驗 退料檢驗 其他

2023年01月29日 版次:A1

料號	DP 卧式贴片	制令單號	/					送檢單位	工程部	首件製作者	裝配		
品名	DP21-0815-G61038	客戶代號	/					批 量	/	送檢時間	/		
								數 量	5PCS	確認時間	/		
抽樣標準		<input checked="" type="checkbox"/> 單次 <input type="checkbox"/> 雙次					抽样数	AQL	CRI:0	MAJ:0.40	MIN:0.65		
MIL-STD-105E(II)		<input checked="" type="checkbox"/> 正常 <input type="checkbox"/> 加嚴 <input type="checkbox"/> 減量					(5PCS)	ACC/REJ	0	/	/		
不良数:		CRI (/) MAJ (/) MIN (/)							不良率(%)		/		
NO.	檢驗項目 單位:MM/G	檢測 儀器	檢 驗 記 錄					品管判定		CRI	MAJ	MIN	備注
			1	2	3	4	5	AC	RE				
	14.50±0.20	D	14.42	14.46	14.45	14.43	14.42	√					
	17.90±0.20	D	17.90	18.01	18.02	18.01	18.02	√					
	16.10±0.05	D	16.14	16.09	16.11	16.10	16.09	√					
	4.76±0.05	D	4.74	4.76	4.72	4.73	4.76	√					
	16.50±0.20	D	16.57	16.53	16.55	16.54	16.56	√					
	5.76±0.20	D	5.80	5.78	5.79	5.80	5.78	√					
	6.65±0.20	D	6.78	6.68	6.75	6.64	6.65	√					
	7.70±0.15	D	7.65	7.71	7.62	7.63	7.65	√					
	6.80±0.15	D	6.80	6.82	6.80	6.79	6.80	√					
檢驗依據: <input checked="" type="checkbox"/> 《工程圖紙》 <input type="checkbox"/> 《檢驗規範》 <input type="checkbox"/> 《承認書》 <input type="checkbox"/> 樣品 <input type="checkbox"/> 其它													
檢測儀器:A游標卡尺 B千分尺 C厚薄儀 D投影鏡 E放大鏡 F顯微鏡 G錫爐 H插拔力器 I間位尺 J其它													
品保判定:													
核 准 APP		欠必鋒			審 核 CHK		/		檢 驗 員 INSPBY		但 芬		

保存期限:三年

保存部門:品保部

QR-M-003

品名:DP 卧式贴片 (端子)		版次:A.0			
电镀规格:Ni30u", Sn100u", Au G/Fu"		日期:2022/6/20			
页次:1/1					
厂商:同华					
测试设备:CMI X-射线膜厚测试仪					
1、底层电镀测试 (Ni)					
数据	测试标准	实测值	判定	测试日期	测试时间
1	30u"MIN	50.5u"	OK	2022/6/20	10:20:15
2	30u"MIN	56.3u"	OK	2022/6/20	10:20:17
3	30u"MIN	67.5u"	OK	2022/6/20	10:20:19
4	30u"MIN	62.4u"	OK	2022/6/20	10:20:21
2、表层电镀测试 (Sn)					
数据	测试标准	实测值	判定	测试日期	测试时间
1	100u"MIN	105.3u"	OK	2022/6/20	10:25:10
2	100u"MIN	104.7u"	OK	2022/6/20	10:25:12
3	100u"MIN	105.9u"	OK	2022/6/20	10:25:14
4	100u"MIN	107.4u"	OK	2022/6/20	10:25:16
3、表层电镀测试 (Au)					
数据	测试标准	实测值	判定	测试日期	测试时间
1	0.5u"MIN	0.55u"	OK	2022/6/20	10:30:32
2	0.5u"MIN	0.52u"	OK	2022/6/20	10:30:34
3	0.5u"MIN	0.56u"	OK	2022/6/20	10:30:36
4	0.5u"MIN	0.54u"	OK	2022/6/20	10:30:38

核准: 欠必锋

审核: 李娟

检验员: 但芬

电镀报告表

品名:DP 卧式贴片 (外壳)		版次:A. 0			
电镀规格:Ni:50u" min		日期:2022/6/16	页次:1/1		
厂商:金和源					
测试设备:CMI X-射线膜厚测试仪					
1、表层电镀测试 (Ni)					
数据	测试标准	实测值	判定	测试日期	测试时间
1	50u"min	56.3u"	OK	2022/6/16	10:42:14
2	50u"min	58.6u"	OK	2022/6/16	10:42:16
3	50u"min	55.4u"	OK	2022/6/16	10:42:18
4	50u"min	54.5u"	OK	2022/6/16	10:42:20

核准: 欠必锋

审核: 李娟

检验员: 但芬

盐水喷雾实验报告

试验方法	盐水喷雾腐蚀试验法	参考资料	MIL-STD-1345
METHOD	NEUTRL SALT SPRAY CORROSION TEST	REF	
客户		试验起始日期	2023年01月28日 20:00 时起
		DATE	2023年01月29日 20:00 时止
样品名称	DP 卧式贴片	试验数量	5PCS
P/N	DP21-0815-G61038	QTY	

试验条件 (TEST CONDITION)

- 1、盐水溶解 (SALT SOLUTION: 浓度 $50 \pm 10\text{g/L}$, PH值6.5-7.2).
- 2、试验室温度 (TEMP. IT THE SPRAY DHAMBR): $35 \pm 1^\circ\text{C}$.
- 3、盐水桶温度 (TEMP. OF SALE SOL' N TANK): $35 \pm 1^\circ\text{C}$.
- 4、压力桶温度 (TEMP. OF SAR SUPPLIERY): $47 \pm 1^\circ\text{C}$.
- 5、试验室相对湿度 (R. H IN THE CHAMBER) 85%.
- 6、压缩空气压力 (COMPRESSED AIR PRESSURE): $1.00 \pm 0.01\text{Kg/cm}^2$.
- 7、样品放置位置 (SPECIMEN SUPPORTED ANGLE): 尼龙绳吊挂 $70^\circ - 90^\circ$.
- 8、喷雾收集量 (COLLECT RATE OF SALT SOL' N) $1-2\text{mL}/(8 \text{ cm}^2\text{hr})$.
- 9、盐雾测试时间: 24小时 (H)

判定方法 (ADFUSGD METHOD)

试验后以20倍放大镜观察、无蓝、绿色腐蚀物之现象 (不包含折弯处), 即判定合格. (Inspext the ecimen at 20 xmagnification no blue or green corrosion products are acceptable)

样品序号	试验后现象 PHENOMENON AFTER TEST	判定 COMMENT
1	无蓝、绿色腐蚀物之现象	OK
2	无蓝、绿色腐蚀物之现象	OK
3	无蓝、绿色腐蚀物之现象	OK
4	无蓝、绿色腐蚀物之现象	OK
5	无蓝、绿色腐蚀物之现象	OK



核准: 欠必锋

审核: 李娟

试验员: 但芬

鉅鼎銅材廠檢驗報告單

公司名稱 Customer	鉅鼎銅材廠檢驗報告單				重量 Weight(kg)	1078	出貨日期 Date	2021/11/23		
品名 Article	標準 Standard No				尺寸 Dimension		狀態 Tenper	銅卷編號 Coil No		
C2680	JISH3100:2017				0.18*400		EH	1021-C-08		
化學成分Chemical Compositions(%)										
元素 Element	Cu %	Zn%	Pb%	Fe%	\	\	\	\	化學成分	雜質
規範 Spec	64.0-68.0	餘量	<0.05	<0.05	\	\	\	\	合格	合格
實測 Actual	64.32	餘量	0.0036	0.0136	\	\	\	\	合格	合格
機械性質Mechanical Properties										
項目 Item	結晶粒度 Grain Size Mm	硬度 Hardness Hv	抗拉強度 TensionStrength Mpa	伸長度 Elongation %	導電率 Electrical Conduc %IACS	彎曲試驗 Bending Test 180	表面粗度 Surface Roughness Ra(u m)	彎曲度 Camber mm/n		
規範MAX Spec	\	170-190	490-610	\	\	\	\	\		
實測 Actual	\	178	574	5	\	\	\	\		

品質部



Materials Information

PRODUCT NAME: LCP M-401 BK

COMPOSITION/INFORMATION OF LCP M-401 BK

SUBSTANCE/MIXTURE: Mixture

SYNONYM(S): Aromatic Liquid Crystal Polymer(LCP)

品名	比例	用途
德众泰 LCP 树脂	0.565	构成材料主要成分
抗氧化剂	0.002	抗氧化
科莱恩热稳定剂	0.003	增加高温稳定性
黑色母	0.01	着色
滑石粉	0.2	增强剂, 增加流动性
玻纤	0.22	增强

NAME OF COMPANY: DZT Engineering Plastics Tech. Co.,Ltd

ADDRESS: Building 2 Zhichong Industrial Park, Hi-Tech Zone, Jiangmen City,
Guangdong Province, China

SECTION IN CHARGE: Quality Assurance Department

TEL/FAX: +86-750-3689920/+86-750-3689921

EMERGENCY TEL: +86-750-3689708

