

REV.	ECN.NO.	APPD.
A	/	weihong
B	E2022071201	魏红

Remark:

- MATERIAL:
  - Housing:thermoplastic plastics.
  - terminals:Copper Alloy
  - Shell:Copper Alloy/SPCC.
- characteristics:
  - Rating Voltage : 30V AC.
  - Rating Current:PIN1&PIN4(Vbus&Correponding ground PIN) 1.8A MAX Other PINS 0.25A min.
  - Contact Resistance:PIN1&PIN4:30 mΩ MAX. Other PINS: 50 mΩ
  - Insulation Resistance:100 MΩ MIN.
  - Withstanding Voltage:AC 100V between adjacent contacts
  - Mating force: 3.57Kgf MAX(35N MAX)
  - Extraction force:1Kgf Min(9.8N Min)
  - Life test:1500Cycles MIN.
  - Temperature Range: -30°C~+80°C.

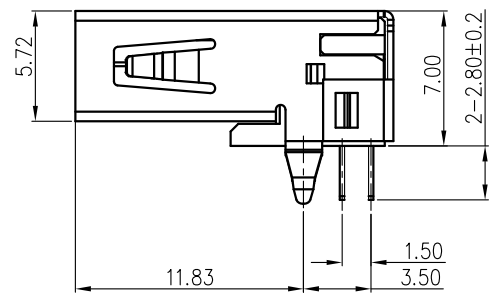
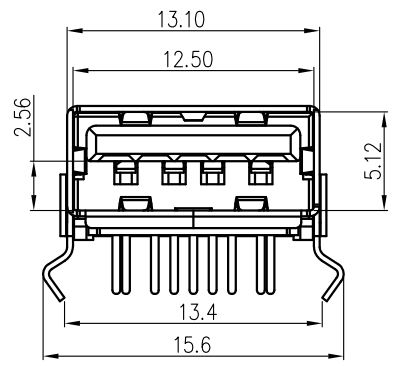
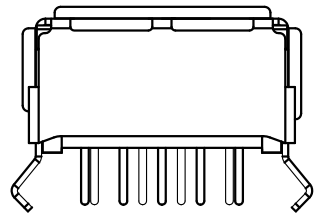
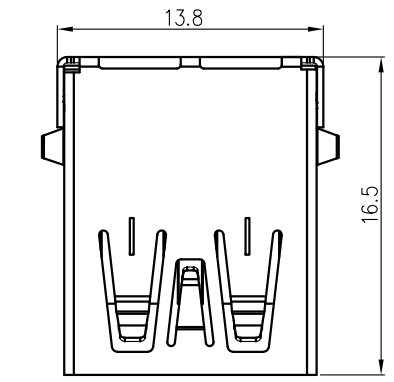

U321-062X-XXX0XX

5:铜壳镀镍  
1:半金1u"  
2:PBT  
1:RoHS 防火  
1:吸塑盒  
7:蓝色300C

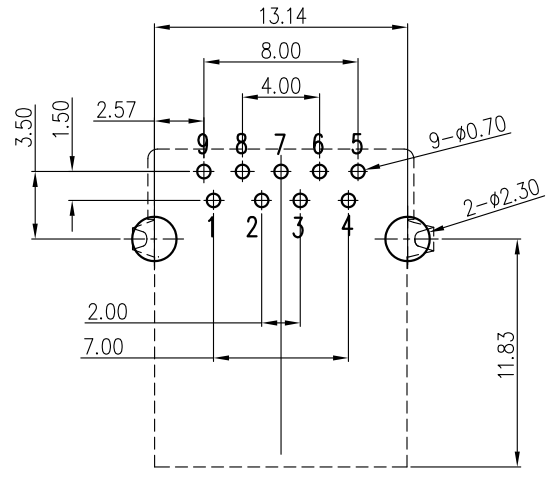
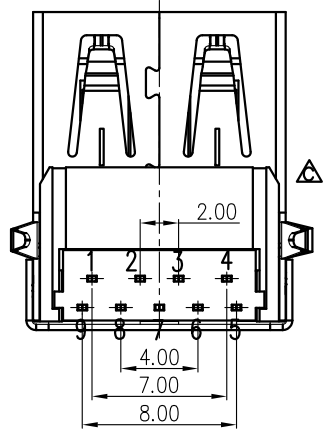

PCB LAYOUT(TOLERANCE±0.05)

TOLERANCE UNLESS OTHERWISE SPECIFIED		FLW 深圳市华联威电子科技有限公司 HUA LIAN WEI TECHNOLOGY ELECTRONICS CO.;LTD.							
.xxx ±0.10	.x' ±3'	APPROVED							
.xx ±0.20	.xx' ±2'					PART NAME:		USB 3.0 AF90度无卷边	
.x ±0.30	.x' ±2'					PART No:		U321-0625-127011 C	
DRAWN	魏红	PROJECTION:	UNIT:	SCALE	SHEET	REV.			
DATE	2022.07.12		mm	1:1	10F1	B			