

REV.	ECN.NO.	APPD.
AO	/	/

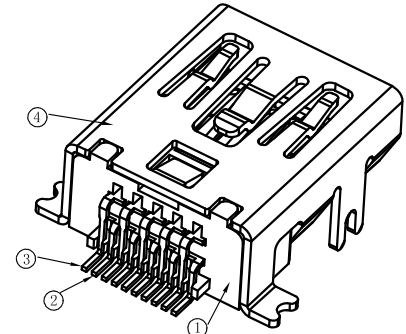

- NOTES:
- MATERIAL:
 - Housing:thermoplastic plastics
 - terminals:Copper Alloy
Gold plated in contact area:
Tin plated in termination
Nickel Plated overall
 - Shell:Steel&Copper Alloy
Nickel/Au Plated overall
 - characteristics:
 - Rating Voltage : 30V AC.
 - Rating Current:
5A for Vbus PIN;1.25A for Vconn PIN
 - Contact Resistance:40 mΩ MAX.
 - Insulation Resistance:100 MΩ MIN.
 - Withstanding Voltage:AC 100V
 - Mating force: 5~20N MAX
 - Extraction force:8~20N Min
 - Life test:10000Cycles MIN.
 - Temperature Range: -30℃~+80℃.
- The product must be compliance ROHS

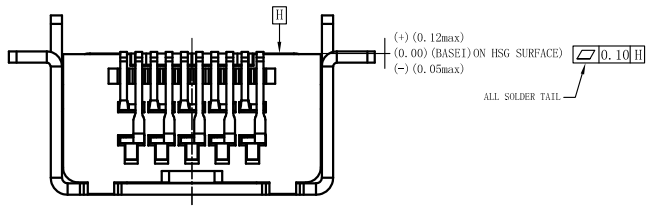
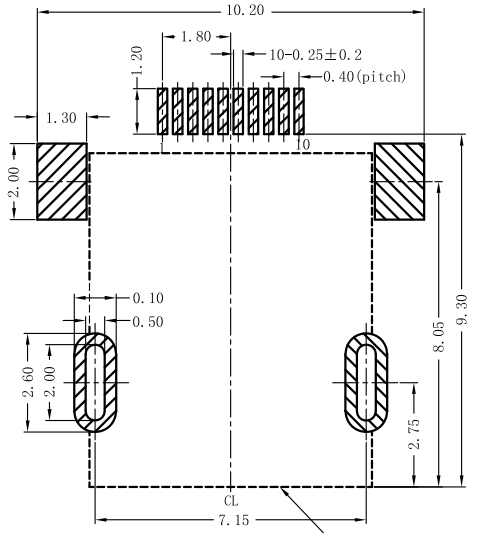
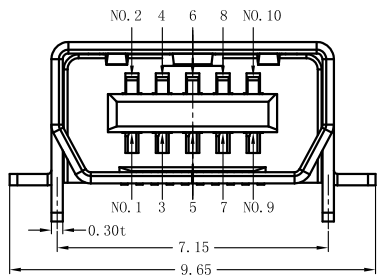
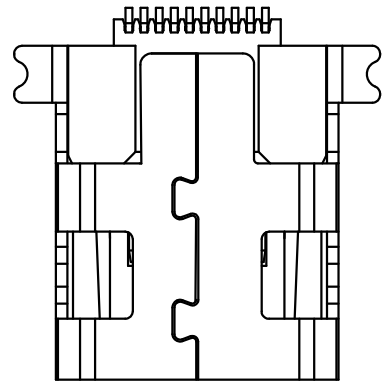
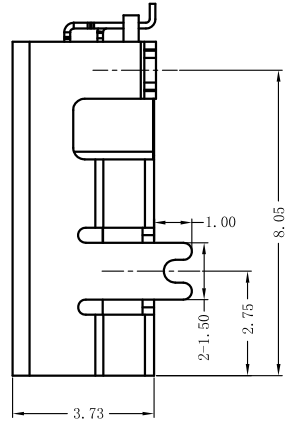
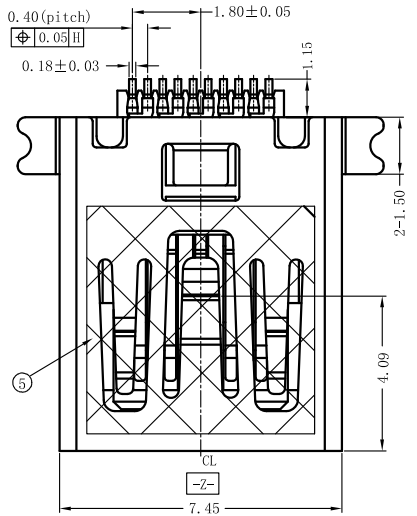

Recommended P.C.B Layout(Top Side)
Tolerance=±0.05

U572-3046-G61038

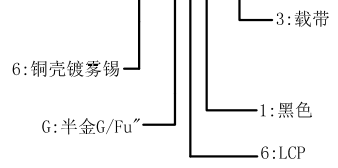

TOLERANCE UNLESS OTHERWISE SPECIFIED		HLW 深圳市华联威电子科技有限公司				
.XXX ±0.10		HUA LIAN WEI TECHNOLOGY ELECTRONICS CO;LTD.				
.XX ±0.20		.X' ±3'				
.X ±0.30		.XX' ±2'				
APPROVED		PART NAME:	飞利浦 10P/F 前插后贴 H款			
CHECKED		PART No:	U572-3046-G61038			C
DRAWN	wei hong	PROJECTION:	UNIT:	SCALE	SHEET	REV.
DATE	2021.7.30		mm	1:1	10F1	AO