

REV.	ECN.NO.	APPD.
A	XXXXXXXXXX	chenyiting

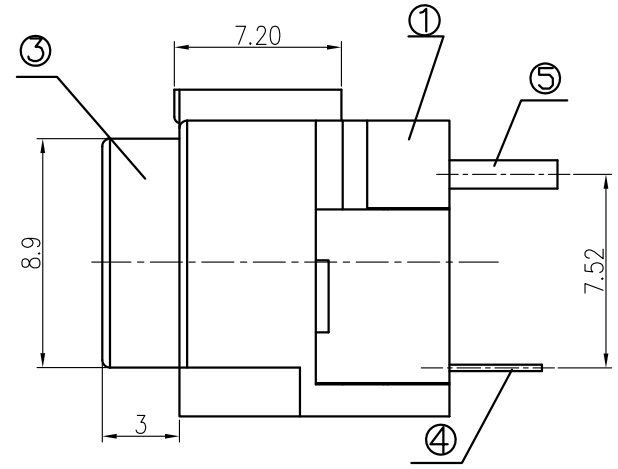

- NOTES:
- MATERIAL:
    - Housing:thermoplastic plastics
    - terminals:Copper Alloy  
Gold plated in contact area:  
Tin plated in termination  
Nickel Plated overall
    - Shell:Steel&Copper Alloy  
Nickel Plated overall
  - ELECTRICAL CHARACTERISTICS:
    - Rating Current :1.5 Ampere
    - Rating Voltage :30 V Max
    - Contact Resistance:30 Milli ohms
    - Insulation Resistance:1000 Mega ohms Min.
  - MECHANICAL CHARACTERISTICS:
    - Connector Mating force: 35N MAX(3.57Kgf)
    - Connector Unmating force:10N min(1.02Kgf)
    - Durability:1500Cycles.
  - ENVIRONMENT CHARACTERISTICS:
    - Operating temperature:-0°C to +50°C
    - Storage temperature:-20°C to +60°C

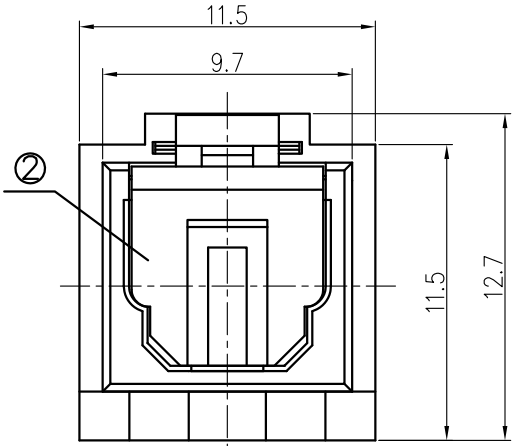
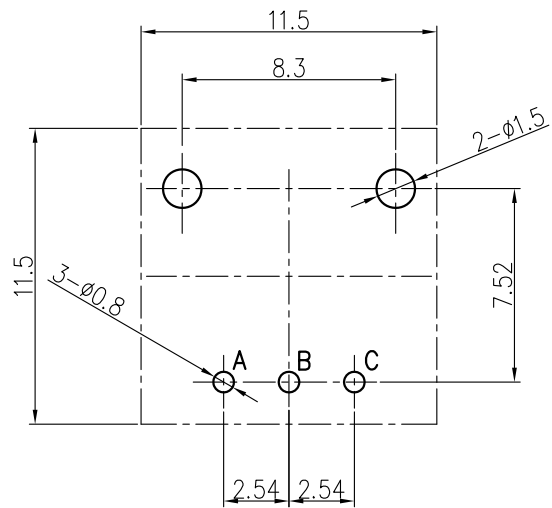
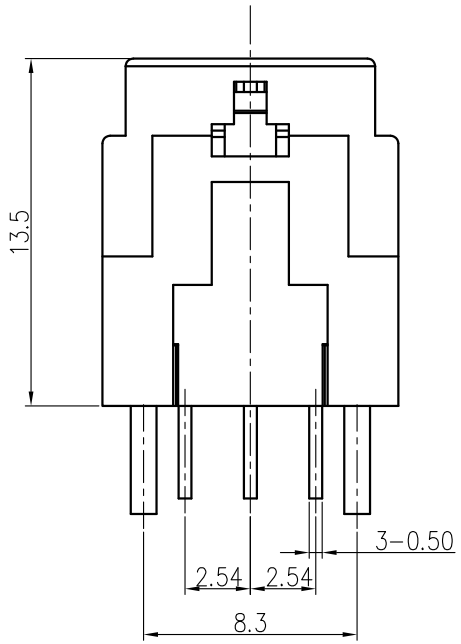

**RECOMMENDED PCB LAYOUT  
TOP VIEW (TOLERANCE:±0.05)**

305205-0010-D118

D: 镀银0.5u"  
1:PA66  
1: 黑色

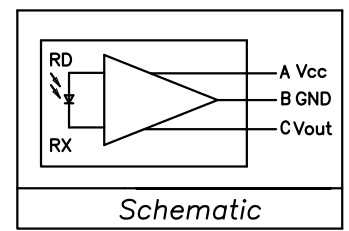

TOLERANCE UNLESS OTHERWISE SPECIFIED		<b>FLW</b> 深圳市华联威电子科技有限公司 HUA LIAN WEI TECHNOLOGY ELECTRONICS CO;LTD.			
.XXX ±0.10	.X' ±3'				
.XX ±0.20	.XX' ±2'	PART NAME:		BF 180度 3P 两脚接收器	
.X ±0.30		PART No:		305205-0010-D118	
APPROVED		PROJECTION:	UNIT:	SCALE:	SHEET:
CHECKED			mm	1:1	1 OF 1
DRAWN	chenyiting				REV.:
DATE	2023.04.03				A