

REV.	ECN.NO.	APPD.
A	EXXXXXXXXXX	Qinyuhua

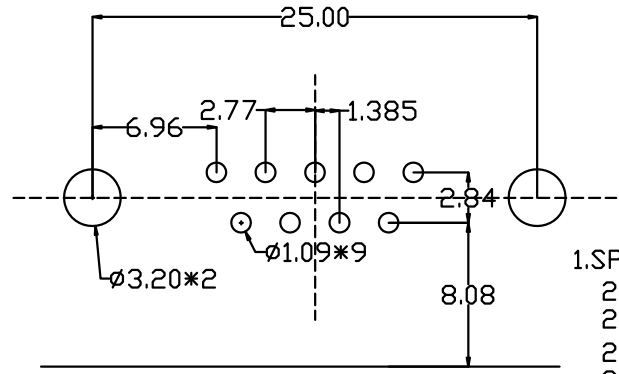
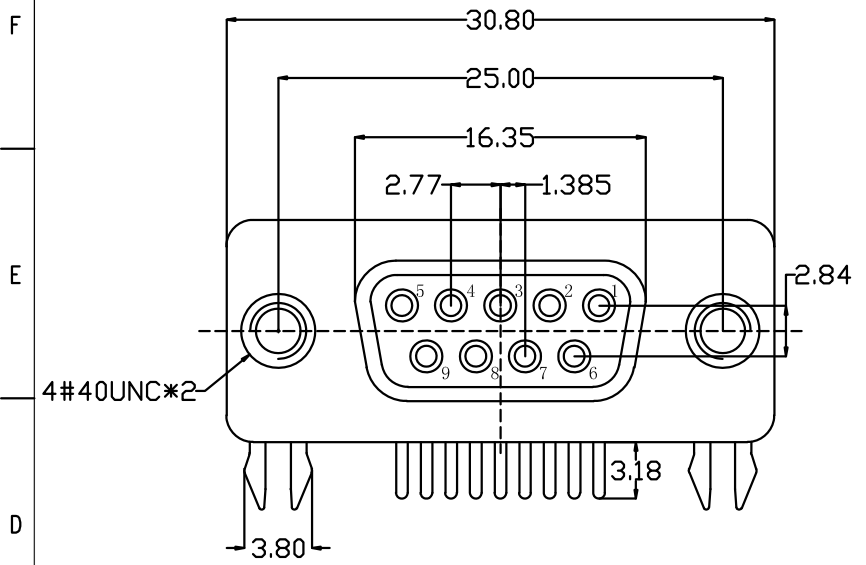

P.C.B LAYOUT

1.SPECIFICATION

- 2.1 Current Rate:5 Amps
- 2.2 Insulator Resistance:1000M Min.
- 2.3 Dielectric Strength:500V AC PER MIN
- 2.4 Operation Temperature:°55C~+105C
- 2.5 Contact Resistance:30m Max

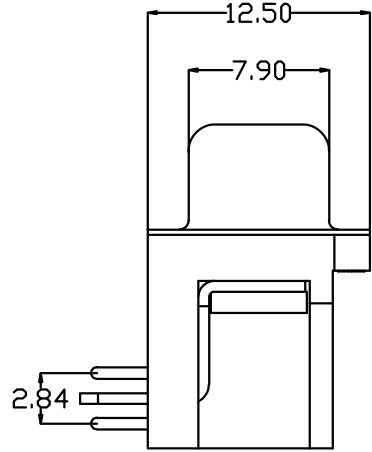
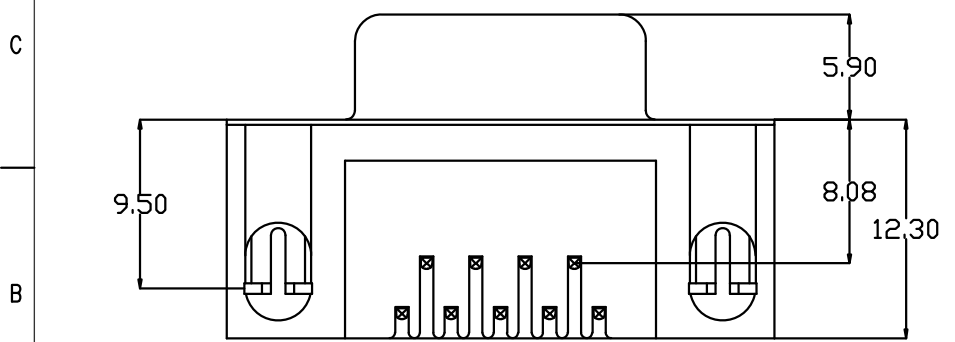

DS211-0100-42A8

- 4: 镀亮锡
- A: 黑色
- 2: PBT

TOLERANCE UNLESS OTHERWISE SPECIFIED		FLW 深圳市华联威电子科技有限公司				
.XXX ±0.10	.XX ±0.20	.X ±0.30	HUA LIAN WEI TECHNOLOGY ELECTRONICS CO;LTD.			
.XX ±0.20	.X ±0.30					
APPROVED		PART NAME:	DR 9母铆合			
CHECKED		PART No:	DS211-0100-42A8	C		
DRAWN	Qinyuhua	PROJECTION:	UNIT:	SCALE	SHEET	REV.
DATE	2023. 05. 30		mm	1:1	10F1	A