

REV.	ECN.NO.	APPD.
A	/	/

NOTES:

1.MATERIAL:

1.1 Housing:thermoplastic plastics

1.2 terminals:Copper Alloy

Gold plated in contact area:

Tin plated in termination

Nickel Plated overall

1.3 Shell:Steel&Copper Alloy

Nickel Plated overall

2.ELECTRICAL CHARACTERISTICS:

2.1 Rating Current :1.5 Ampere

2.2 Rating Voltage :30 V Max

2.3 Contact Resistance:30 Milli ohms

2.4 Insulation Resistance:1000 Mega ohms Min.

3.MECHANICAL CHARACTERISTICS:

3.1 Connector Mating force: 35N MAX(3.57Kgf)

3.2 Connector Unmating force:10N min(1.02Kgf)

3.3 Durability:1500Cycles.

4.ENVIRONMENT CHARACTERISTICS:

4.1 Operating temperature:-0°C to +50°C

4.2 Storage temperature:-20°C to +60°C

U221-6611-G61017

1:铁壳镀镍

G:半金G/Fu"

1:吸塑盒

1:黑色

6:LCP

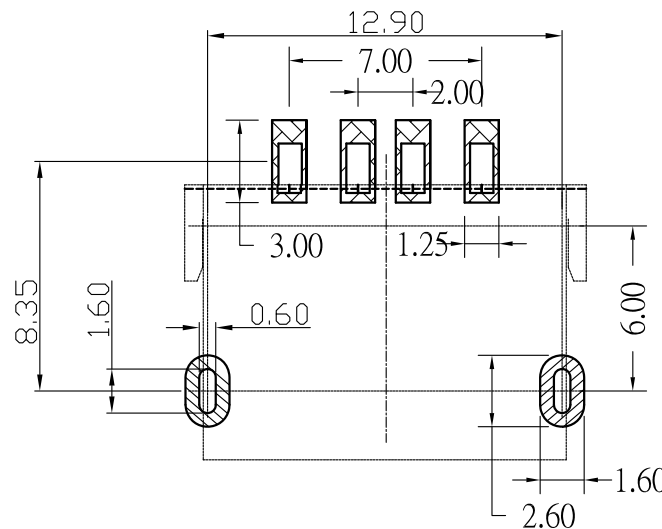
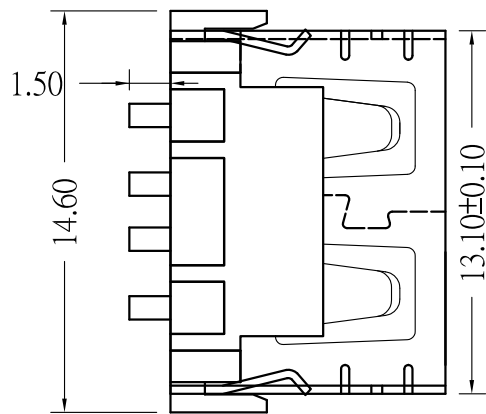
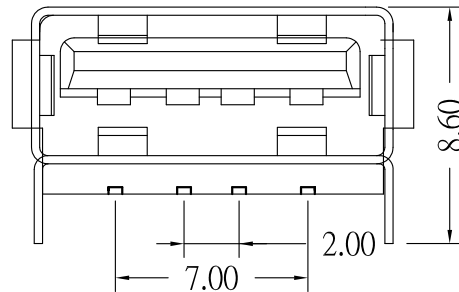
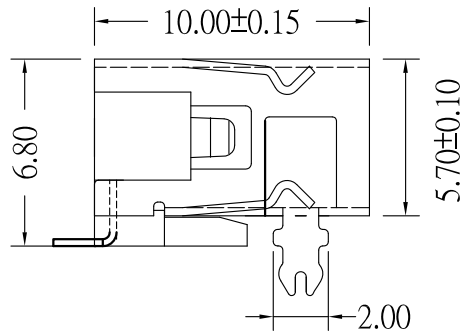

RECOMMENDED P. C. B LAYOUT

TOLERANCE UNLESS OTHERWISE SPECIFIED		<b>FLW</b> 深圳市华联威电子科技有限公司				
.XXX ±0.10 .XX ±0.20 .X ±0.30		.X ±3° .XX ±2°		HUA LIAN WEI TECHNOLOGY ELECTRONICS CO.;LTD.		
APPROVED		PART NAME:	USB AF 短体6.8 两脚直边贴板 黑铁			
CHECKED		PART No:	U221-6611-G61017			C
DRAWN	weihong	PROJECTION:	UNIT:	SCALE	SHEET	REV.
DATE	2021.9.23		mm	1:1	10F1	A