

REV.	ECN.NO.	APPD.
A	/	/

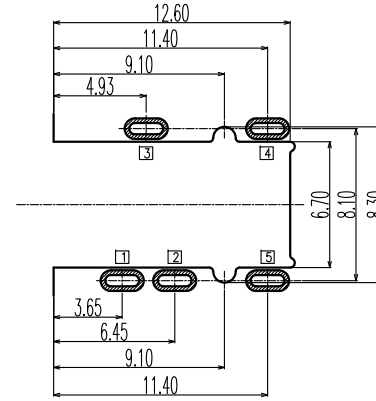

RECOMMENDED P.C.B LAYOUT
TOP VIEW (TOLRANCE:±0.05)

1. CURRENT RATING : 1.0 AMP. MAX.
2. DIELECTRIC WITHSTANDING : AC 500V/min R. M. S.
3. INSULATION RESISTANCE : 100MΩ min. AT 100V DC.
4. CONTACT RESISTANCE : 50mΩ MAX.
5. OPERATING TEMPERATURE : -25° C TO +85° C.
6. DURABILITY : 1500 CYCLES.
7. MATING FORCE : 3kgs MAX
8. UNMATING FORCE : 0.3~3.0kgs
9. MAX PROCESSING TEMPERATURE :
60 SECONDS IN 230° C AND 10 SECONDS IN 260° C

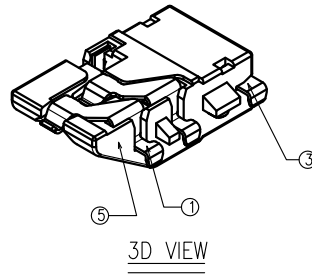
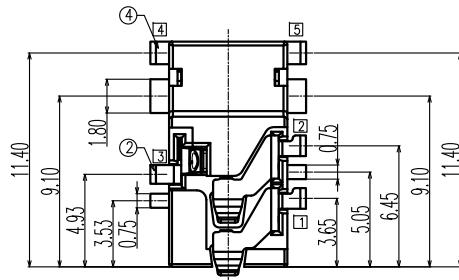
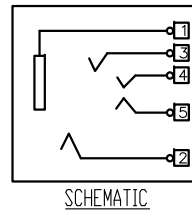
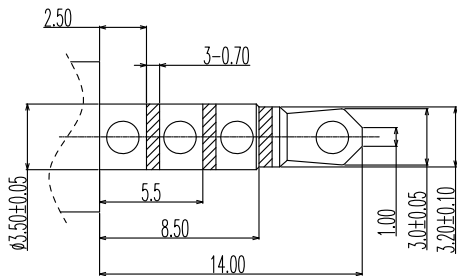
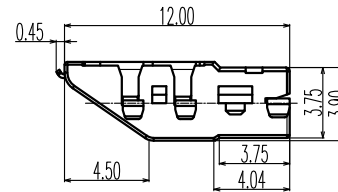
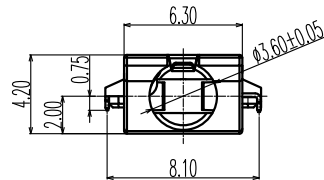

JK1-157-XXX7
C:半金G/Fu” 1:黑色
2:PBT

5	HOUSING	1	HIGH TEMP PLASTIC,COLOR BLACK	
4	TERMINAL 4	1	PHOSPHOR BRONZE; NICKEL UNDER PLATING OVERALL,GOLD PLATING ON SOLDER AREA;GOLD PLATING ON CONTACT AREA.	
3	TERMINAL 3	1	PHOSPHOR BRONZE; NICKEL UNDER PLATING OVERALL,GOLD PLATING ON SOLDER AREA;GOLD PLATING ON CONTACT AREA.	
2	TERMINAL 2	1	PHOSPHOR BRONZE; NICKEL UNDER PLATING OVERALL,GOLD PLATING ON SOLDER AREA;GOLD PLATING ON CONTACT AREA.	
1	TERMINAL 1	2	PHOSPHOR BRONZE; NICKEL UNDER PLATING OVERALL,GOLD PLATING ON SOLDER AREA;GOLD PLATING ON CONTACT AREA.	
ITEM	NAME	QTY	DESCRIPTION	NOTE

TOLERANCE UNLESS OTHERWISE SPECIFIED		FLW 深圳市华联威电子科技有限公司				
.XXX ±0.10	.X' ±3'	HUA LIAN WEI TECHNOLOGY ELECTRONICS CO;LTD.				
.XX ±0.20	.XX' ±2'					
.X ±0.30						
APPROVED		PART NAME:	耳机沉板2.0			
CHECKED		PART No:	JK1-157-C217	C		
DRAWN	weihong	PROJECTION:	UNIT:	SCALE	SHEET	
DATE	2021. 9. 23		mm	1:1	10F1	
					REV. A	