

REV.	ECN.NO.	APPD.
A	/	/

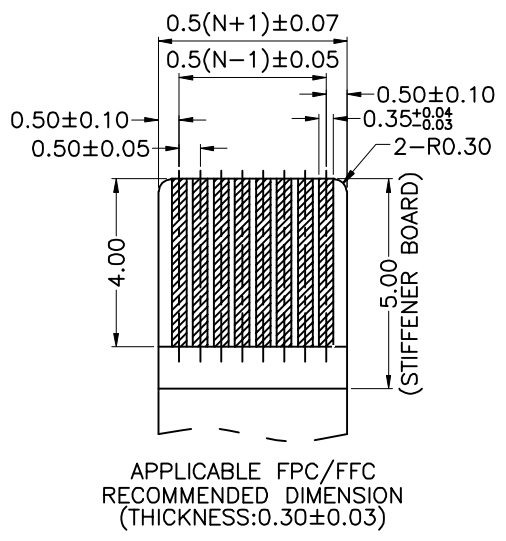

APPLICABLE FPC/FFC
RECOMMENDED DIMENSION
(THICKNESS:0.30±0.03)

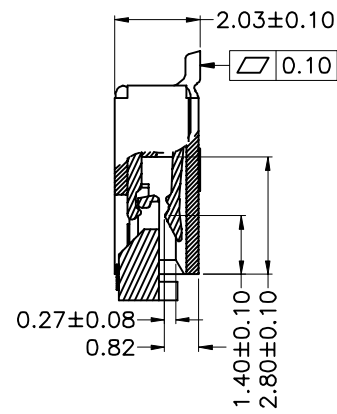
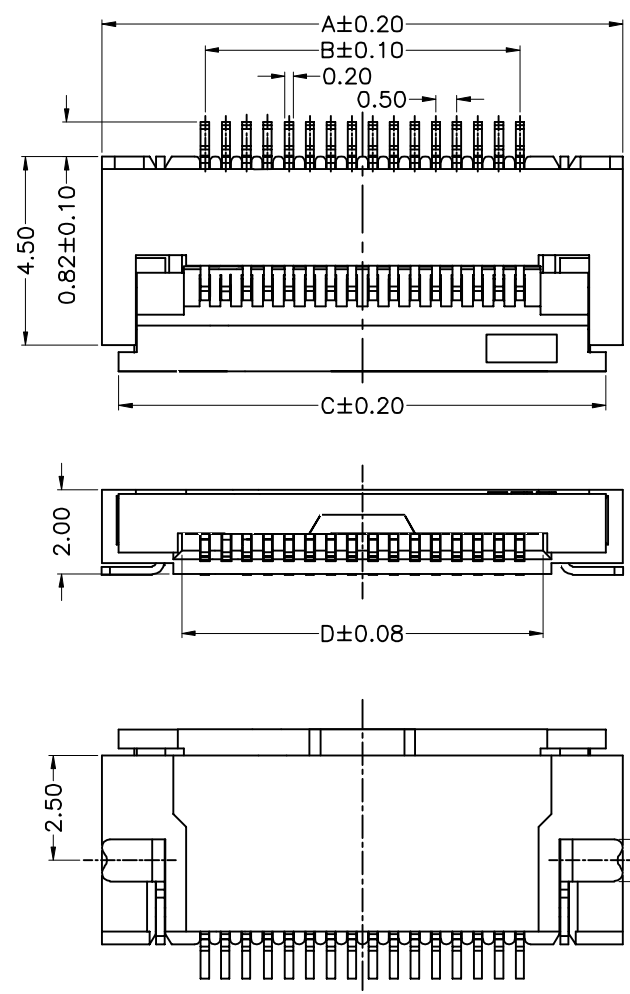
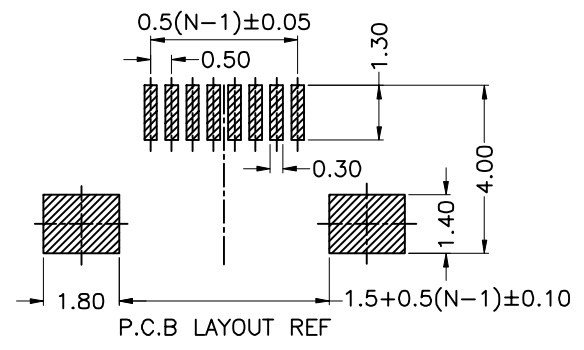

50	29.40	24.50	28.50	25.60
49	28.90	24.00	28.00	25.10
48	28.40	23.50	27.50	24.60
47	27.90	23.00	27.00	24.10
46	27.40	22.50	26.50	23.60
45	26.90	22.00	26.00	23.10
44	26.40	21.50	25.50	22.60
43	25.90	21.00	25.00	22.10
42	25.40	20.50	24.50	21.60
41	24.90	20.00	24.00	21.10
40	24.40	19.50	23.50	20.60
39	23.90	19.00	23.00	20.10
38	23.40	18.50	22.50	19.60
37	22.90	18.00	22.00	19.10
36	22.40	17.50	21.50	18.60
35	21.90	17.00	21.00	18.10
34	21.40	16.50	20.50	17.60
33	20.90	16.00	20.00	17.10
32	20.40	15.50	19.50	16.60
31	19.90	15.00	19.00	16.10
30	19.40	14.50	18.50	15.60
29	18.90	14.00	18.00	15.10
28	18.40	13.50	17.50	14.60
27	17.90	13.00	17.00	14.10
26	17.40	12.50	16.50	13.60
25	16.90	12.00	16.00	13.10
24	16.40	11.50	15.50	12.60
23	15.90	11.00	15.00	12.10
22	15.40	10.50	14.50	11.60
21	14.90	10.00	14.00	11.10
20	14.40	9.50	13.50	10.60
19	13.90	9.00	13.00	10.10
18	13.40	8.50	12.50	9.60
17	12.90	8.00	12.00	9.10
16	12.40	7.50	11.50	8.60
15	11.90	7.00	11.00	8.10
14	11.40	6.50	10.50	7.60
13	10.90	6.00	10.00	7.10
12	10.40	5.50	9.50	6.60
11	9.90	5.00	9.00	6.10
10	9.40	4.50	8.50	5.60
9	8.90	4.00	8.00	5.10
8	8.40	3.50	7.50	4.60
7	7.90	3.00	7.00	4.10
6	7.40	2.50	6.50	3.60
5	6.90	2.00	6.00	3.10
4	6.40	1.50	5.50	2.60
No. of Contacts	A	B	C	D
	Dimension			

- 1.MATERIAL:
 1.1 HOUSING: LCP,UL94V-0; COLOR: NATURE.
 1.2 ACTUATOR: LCP,UL94V-0; COLOR: BLACK.
 1.3 CONTACT: C5191,T=0.20±0.01mm
 1.4 SOLDER PAD: C2680,T=0.20±0.01mm
- 2.FINISH:
 2.1 CONTACT:100u" MIN. TIN PLATED IN SOLDER AREA
 50u" MIN. NICKEL UNDERPLATED OVERALL.
 2.2 SOLDER PAD: 50u" MIN. NICKEL PLATED OVERALL.
 100u" MIN. TIN PLATED OVERALL.

TOLERANCE UNLESS OTHERWISE SPECIFIED	
.XXX ±0.10	.X' ±3'
.XX ±0.20	.XX' ±2'
.X ±0.30	
APPROVED	
CHECKED	
DRAWN	weihong
DATE	2021.9.23

FLW 深圳市华联威电子科技有限公司
 HUA LIAN WEI TECHNOLOGY ELECTRONICS CO;LTD.

PART NAME:	FPC 2.0间距0.5翻盖 30P				
PART No:	FP4101-01268				C
PROJECTION:	UNIT:	SCALE:	SHEET:	REV.	
	mm	1:1	10F1	A	