

9

8

7

6

5

4

3

2

1

REV.	ECN.NO.	APPD.
A	/	/

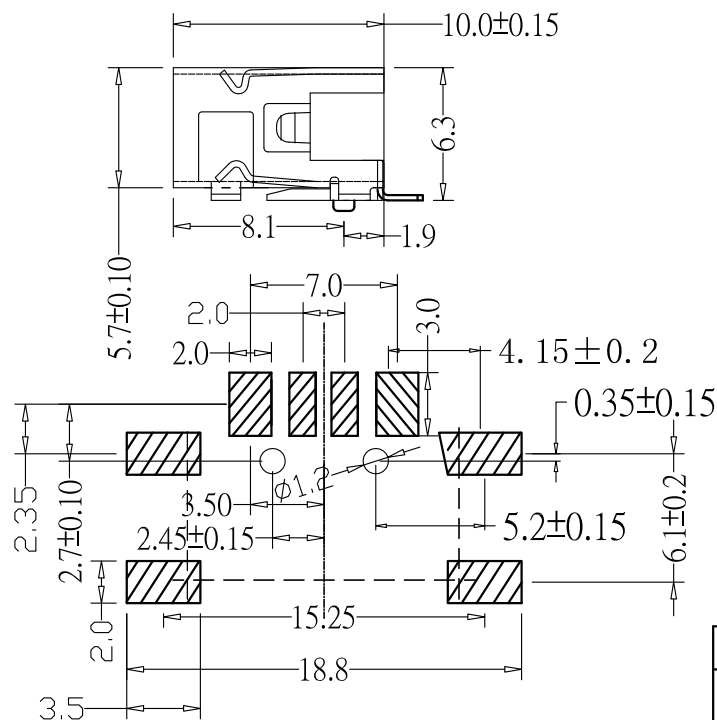
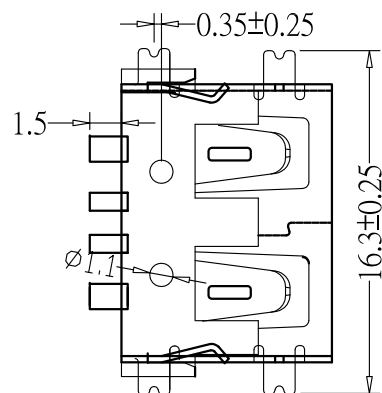
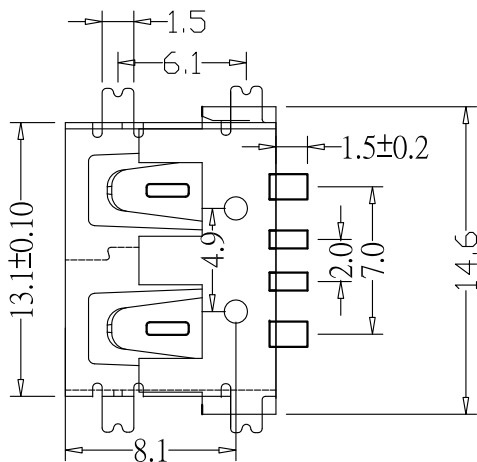
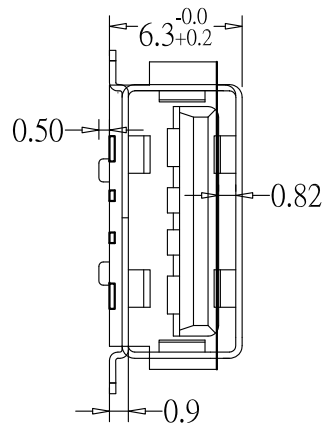

NOTES:

1.MATERIAL:

- 1.1 Housing:thermoplastic plastics
- 1.2 terminals:Copper Alloy
Gold plated in contact area:
Tin plated in termination
Nickel Plated overall
- 1.3 Shell:Steel&Copper Alloy
Nickel Plated overall

2.ELECTRICAL CHARACTERISTICS:

- 2.1 Rating Current :1.5 Ampere
- 2.2 Rating Voltage :30 V Max
- 2.3 Contact Resistance:30 Milli ohms
- 2.4 Insulation Resistance:1000 Mega ohms Min.

3.MECHANICAL CHARACTERISTICS:

- 3.1 Connector Mating force: 35N MAX(3.57Kgf)
- 3.2 Connector Unmating force:10N min(1.02Kgf)
- 3.3 Durability:1500Cycles.

4.ENVIRONMENT CHARACTERISTICS:

- 4.1 Operating temperature:-0°C to +50°C
- 4.2 Storage temperature:-20°C to +60°C

U222-5831-G21017

1:铁壳镀镍
G:半金G/Fu"
2:PBT

1:吸塑盒
1:黑色

TOLERANCE UNLESS OTHERWISE SPECIFIED		HLW 深圳市华联威电子科技有限公司				
		HUA LIAN WEI TECHNOLOGY ELECTRONICS CO.;LTD.				
.XXX ±0.10	.X' ±3'	APPROVED	PART NAME: USB AF 短体10.0 高度6.3全贴片大电流			
.XX ±0.20	.XX' ±2'	CHECKED	PART No: U222-5831-G21017			C
.X ±0.30		DRAWN weihong	PROJECTION:	UNIT:	SCALE	SHEET
		DATE 2021.11.06		mm	1:1	10F1
						REV. A

9

8

7

6

5

4

3

2

1