

## 承 认 书

Approval Sheet

客户 (Customer): /

客户料号 (Cus .P/N): /

华联威料号 (HLW P/N): HD27-071B-G61018

品名规格 (PronameSpec): HDMI 19P/F 沉板反向高度 2.99

送样日期 (Delivery Date): 2022/04/11

承认日期 (Acknowledge Date): 2022/04/11

Approved No:		客 户 Customer	
采 购 部 Purchasing Dept	品 质 部 QC Dept	工 程 部 Engineering Dept	确 认 Approved By
深 圳 市 华 联 威 电 子 科 技 有 限 公 司 SHEN ZHEN SHI HUA LIAN WEI ELECTRONICS TECHNOLOGY CO; LTD.			
业 务 部 Sales Dept	品 管 部 QC Dept	工 程 部 Engineering Dept	核 准 Checked By
陈虹熹	欠必锋	魏红	唐竹君

地址: 深圳市龙华区观澜街道桂香社区观澜桂花路 307 号

TEL: 0755-28888886 28888866

邮箱: hua@hlwconn.com

[Http://www.hlwconn.com](http://www.hlwconn.com)

# 目 录

## Contents

图纸.....	Page03
产品规格书.....	Page04-09
产品检测报告.....	Page10-11
尺寸测试报告.....	Page12
电镀报告.....	Page13-14
盐雾报告.....	Page15
材质证明.....	Page16-18
SGS.....	Page19-56

REV.	ECN.NO.	APPD.
A	/	/

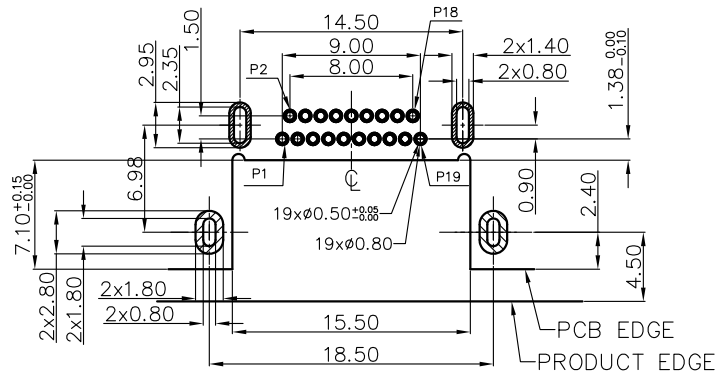
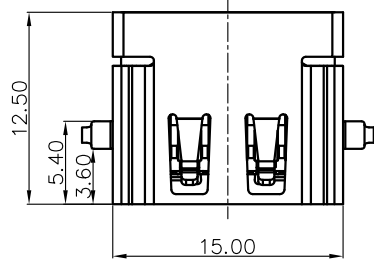

RECOMMENDED PCB LAYOUT T=1.20  
GENERAL TOLERANCES:±0.05

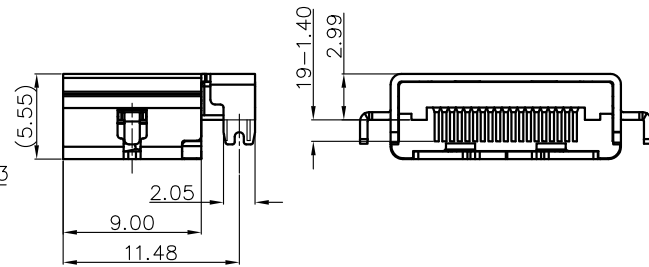
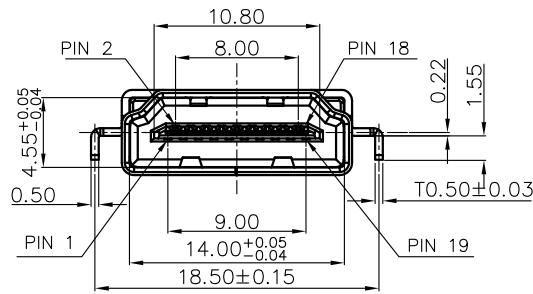

NOTES:

- MATERIAL:
  - Housing:thermoplastic plastics
  - terminals:Copper Alloy  
Gold plated in contact area:  
Tin plated in termination  
Nickel Plated overall
  - Shell:Steel&Copper Alloy  
Nickel/Au Plated overall
- ELECTRICAL CHARACTERISTICS:
  - Rating Current :0.5 Ampere
  - Rating Voltage :40 V Max
  - Contact Resistance:30 Milli ohms
  - Insulation Resistance:100 Mega ohms Min.
- MECHANICAL CHARACTERISTICS:
  - Connector Mating force: 4.5kg MAX
  - Connector Unmating force:1.0Kg min
  - Durability:10000Cycles.
- ENVIRONMENT CHARACTERISTICS:
  - Operating temperature:-20°C to +85°C
  - Storage temperature:-20°C to +65°C

HD27-071B-G61018

B:不锈钢镀镍  
G:半金G/Fu  
1:吸塑盒  
1:黑色  
6:LCP

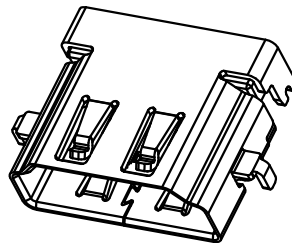
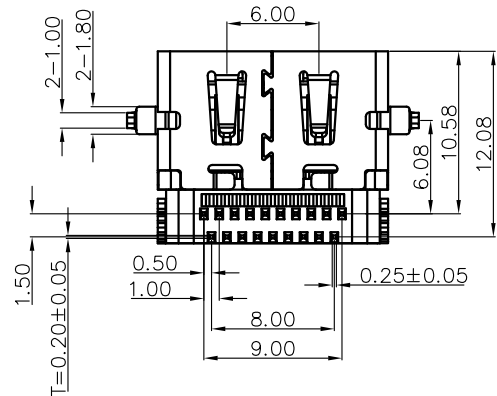

TOLERANCE UNLESS OTHERWISE SPECIFIED		<b>FLW 深圳市华联威电子科技有限公司</b>					
.XXX ±0.10 .XX ±0.20 .X ±0.30		.X' ±3' .XX' ±2'		HUA LIAN WEI TECHNOLOGY ELECTRONICS CO;LTD.			
APPROVED		PART NAME:	HDMI 19P/F沉板反向H2.99				
CHECKED		PART No:	HD27-071B-G61018	C			
DRAWN	weihong	PROJECTION:	UNIT:	SCALE	SHEET	REV.	
DATE	2021.7.23		mm	1:1	10F1	A	

## HDMI系列产品SPEC

版本版次: C

制定日期 20200707

适用范围 通用

## 1. Scope (范围)

## 1.1 Contents(内容)

This specification covers the performance, tests and quality requirements for the Electronics HDMI Connector.  
(此份产品规格适用于HDMI连接器的产品功能, 测试方法及质量要求)

## 2. Requirements (要求):

## 2.1 Rating(额定条件)

A. Voltage rating(额定电压):40V AC

B. Current rating(额定电流):0.5A

C. Operation Temperature Range(操作温度范围):-30°C to +85°C

## 3. Test Condition(测试条件):

3.1 Temperature range(温度范围):+15°C to +35°C

3.2 Humidity range (湿度范围):25% to 85%

## 4. Test Methods and Requirements:(测试方法及要求)

## 4.1 Examination of product (产品外观)

4.1.1	Examination of Product 产品外观	Visual 目视	No peeling off the plating deformation of the base or damage. 不得有电镀层剥落, 塑料变形或破损
-------	--------------------------------	--------------	---

## 4.2. Electrical Performance(电气性能)

4.2.1	Contact Resistance 接触阻抗	(EIA-364-06B) Mated connectors, Contact: measure by dry circuit, 20 m Volts maximum, 10 mA Shell: measure by open circuit, 5 Volts maximum, 100 mA 配对的连接器, 端子: 测试端子在回路中施加直流最大20mV 10mA的电流再测端子的电阻值 外壳: 测试外壳在开路中施加电流最大5V 100mA的电流再测外壳的电阻值	Initial Contact resistance Excluding conductor Resistance:30 mΩ max (Target design value)  接触电阻初始值最大不能超过30 mΩ (目标设计值)
4.2.2	Dielectric Withstanding Voltage (耐电压)	(EIA-364-20C) Unmated connectors, apply 500V AC (RMS.) for 1 minute between adjacent terminals of ground. Mated connectors, apply 300V AC (RMS.) for 1 minute between adjacent terminals of ground. 没有配对的连接器在相邻的端子或接地之间通上500V的交流电压1分钟 配对的连接器在相邻的端子或接地之间通上300V的交流电压1分钟	1. No Breakdown or flashover 2. Leakage current:0.5mA Max  1. 不能有损坏或跳火花 2. 漏电流<0.5mA

4.2.3	Insulation Resistance 绝缘阻抗	(EIA-364-21C) Unmated connectors, apply 500V DC for 1 minute between adjacent terminals of ground. Mated connectors, apply 100V DC for 1 minute between adjacent terminals of ground. 没有配对的连接器在相邻的端子或接地之间通上500V的直流电压1分钟 配对的连接器在相邻的端子或接地之间通上150V的直流电压1分钟	100MΩ min (unmated) 10 MΩ min (mated) 没有配对需大于100 MΩ 配对需大于10 MΩ
4.3 Mechanical Performance(机械性能)			
4.3.1	Insertion/Withdrawal Force 插入力/拔出力	(EIA-364-13) Insertion and withdrawal speed: 25mm/minute. 插入和拔出的速度为25mm/分	Maximum insertion force 44.1N 插入力不超过44.1N(4.5kg) Withdrawal force 9.8N min 39.2N max 拔出力9.8-39.2N(1.0-4.0kg)
4.3.2	Durability 寿命测试	(EIA-364-09) Measure contact and shell resistance after the following. Automatic cycling: 10000 cycles at 100±5 Cycles per hour. 以每小时100±5的插拔次数测试10000循环后测量端子和外壳的接触阻抗	Contact Resistance 接触阻抗 Contact: Change from initial Value: 30 milliohms maximum. Shell: Change from initial Value: 50 milliohms maximum. 端子: 从初始值开始变化量小于30mΩ 外壳: 从初始值开始变化量小于50mΩ
4.3.3	Vibration 振动	(EIA-364-28条件3) Amplitude: 1.52mm P-P or 147m/s <sup>2</sup> {15G} Sweep time: 50-2000-50Hz in 20 minutes. Duration: 12 times in each (total of 36 times) X, Y, Z, axes. Electrical load DC 100mA current shall be flowed during the test.(ANSI/EIA-364-28 Condition III) 在直流100毫安通电状态下测试, 在X,Y,Z垂直3方向上, 频率50-2000-50赫兹(加速度往复20分钟), 全振幅1.52mm P-P或147 m/s <sup>2</sup> {15G}, 每轴12回计36回	Appearance: No damage 外观: 无损坏 Contact Resistance 接触阻抗 Contact: Change from initial Value: 30mΩ Max. 端子: 从初始值开始变化量小于30mΩ Shell Part: Change from initial Value: 50mΩ Max. 外壳: 从初始值开始变化量小于50 mΩ Discontinuity: 1μ sec Max. 间断性: 不超过1微秒
4.3.4	Physical shock 冲击性	(EIA-364-27条件A) Pulse width: 11msec Waveform: Half-sine 490m/s <sup>2</sup> (50G) 3 strokes in each X, Y, Z axes. (ANSI/EIA-364-27 condition A) 周期: 11msec 冲击波形: 正弦半波490m/s <sup>2</sup> (50G) 3循环在X, Y, Z 轴	Appearance: No damage 外观: 无损坏 Contact Resistance 接触阻抗 Contact: Change from initial Value 30mΩ Max 端子: 从初始值开始变化量小于30mΩ Shell Part: Change from initial Value 50mΩ Max 外壳: 从初始值开始变化量小于50mΩ Discontinuity: 1μ sec Max. 间断性: 不超过1微秒
4.4 Environmental Performance			

4.4..1	Thermal shock test 冷热冲击	EIA-364-32C条件1) 10 cycles of: a)-55±3℃ for 30 minutes b) +85±3℃ for 30 minutes 10个循环, a)-55±3℃ 30 分钟 b) +85±3℃ 30 分钟	Appearance: No Damage. 外观: 没有损坏 Contact Resistance 接触阻抗 Contact: Change from initial Value 30mΩ Max Shell Part: Change from initial Value 50mΩ Max 端子: 从初始值开始变化量小于30mΩ 外壳: 从初始值开始变化量小于50mΩ
4.4..2	Solder ability 焊锡性	(EIA-364-52) To be sipped in the solder bath 260±5℃ Coverage for 3 seconds.将焊锡脚浸在260±5℃的锡炉中<3秒	The inspected area of each lead must have 90% solder coverage minimum 表面粘锡面积不少于90%
4.4..3	Humidity 恒温恒湿	(EIA-364-31B) (A) Mate connectors together and perform the test as follows 配对的连接器测试条件 Temperature: -25℃ to +85℃(温度: -25℃到+85℃) Relative Humidity: 80% to 90%(相对湿度: 80%到90%) Duration:4 cycles(96 hours) (持续时间: 4个循环共96小时) Upon completion of the test, specimens shall be conditioned ambient room conditions for 24 hours, after which the specified measurements shall be performed. 试验完成后, 样品放置于室温条件中24小时后再进行测试	Appearance: No Damage 外观, 没有损坏 Contact Resistance 接触阻抗 Contact: Change from initial Value 30mΩ Max Shell Part: Change from initial Value 50mΩ Max 端子: 从初始值开始变化量小于30mΩ 外壳: 从初始值开始变化量小于50mΩ
		(EIA-364-31B) (B) Unmated each connector and perform the test as follows. 没有配对的连接器测试条件 Temperature: +25℃ to +85℃(温度: +25℃到+85℃) Relative Humidity: 80% to 90%(相对湿度: 80%到90%) Duration:4 cycles(96 hours) (持续时间: 4个循环共96小时) Upon completion of the test, specimens shall be conditioned ambient room conditions for 24 hours, after which the specified measurements shall be performed. 试验完成后, 样品放置于室温条件中24小时后再进行测试	Appearance: No Damage 外观, 没有损坏 Conform to item of dielectric withstanding Voltage and Insulation Resistance. 符合耐电压及绝缘阻抗要求

4.4.4	Salt Spray 盐水喷雾	<p>(EIA-364-26B)  Temperature: 35±2℃ 温度: 35±2℃  Concentration for salt: 5% 盐水浓度: 5%  (1)Duration: 24H 持续时间: 24小时  Condition(条件):  Contact plated gold more than 15u" (include 15 u" ),and the material of shell for copper alloy, or stainless.  端子镀金厚度大于等于15 u" 且壳体材质是铜合金或是不锈钢  (2) Duration: 24H 持续时间: 24小时  Condition(条件):  Contact plated gold less than 15 u" ,and/or the material of shell for steel  端子镀金厚度小于15u" 且/或壳体材质是铁</p>	<p>No detrimental corrosion( Terminal solder tail unrequested)  产品无氧化, 锈蚀(端子焊脚镀锡处不作要求)  Contact Resistance 接触阻抗  Contact: Change from initial Value 30mΩ Max  Shell Part: Change from initial Value 50mΩ Max  端子: 从初始值开始变化量小于30mΩ  外壳: 从初始值开始变化量小于50mΩ</p>
4.4.5	Cold resistance (Unmated) 冷阻抗	<p>(EIA-364-17B)  Unmated connectors and expose to -40±3℃ for 250 hours. Upon completion of the exposure period, the test specimens shall be conditioned at ambient room conditions for 1 to 2 hours, after which the specified measurements shall be performed.  没配对的连接器放置于-40±3℃温度中250小时, 当完成实验后, 样品放置一般环境中1到2小时后, 在进行测试</p>	<p>Appearance: No Damage.  外观: 没有损坏  Contact Resistance 接触阻抗  Contact: Change from initial Value 30mΩ Max  Shell Part: Change from initial Value 50mΩ Max  端子: 从初始值开始变化量小于30mΩ  外壳: 从初始值开始变化量小于50mΩ</p>
4.4.6	Heat resistance (Unmated) 热阻抗	<p>(EIA-364-17B)  Mated connectors and expose to 85±2℃ for 96 hours. Upon completion of the exposure period, the test specimens shall be conditioned at ambient room conditions for 1 to 2 hours, after which the specified measurements shall be performed.  配对的连接器放置于85±2℃温度中96小时, 当完成实验后, 样品放置一般环境中1到2小时后, 在进行测试</p>	<p>Appearance: No Damage.  外观: 没有损坏  Contact Resistance 接触阻抗  Contact: Change from initial Value 30mΩ Max  Shell Part: Change from initial Value 50mΩ Max  端子: 从初始值开始变化量小于30mΩ  外壳: 从初始值开始变化量小于50mΩ</p>
4.4.7	Thermal Aging 高温老化	<p>(EIA-364-31B, Condition 4, Method A)  Unmated connectors and expose to +105±2℃ for 250 hours. Upon completion of the exposure period, the test specimens shall be conditioned at ambient room conditions for 1 to 2 hours, after which the specified measurements shall be performed.  没配对的连接器放置于+105±2℃温度中250小时, 当完成实验后, 样品放置一般环境中1到</p>	<p>Appearance: No Damage.  外观: 没有损坏  Contact Resistance 接触阻抗  Contact: Change from initial Value 30mΩ Max  Shell Part: Change from initial Value 50mΩ Max  端子: 从初始值开始变化量小于30mΩ  外壳: 从初始值开始变化量小于50mΩ</p>

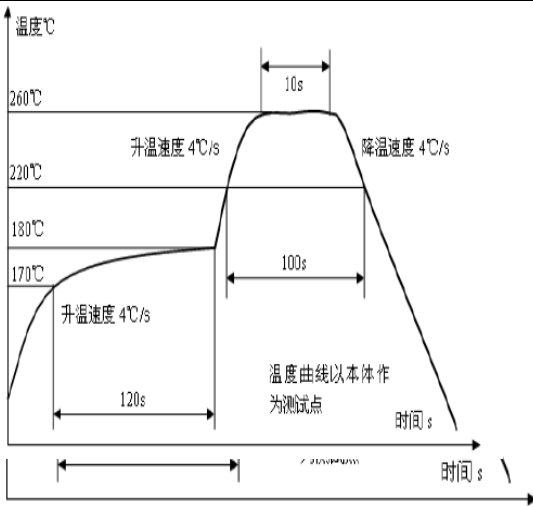
4.4.8	Resistance to Soldering Heat	<p>for wave soldering : mil-std-202f,method 210 A,test condition B          波峰焊: mil-std-202f, method 210 A, 试验条件B          Pre-heat : 80℃, 60 Seconds 预热:80℃, 60秒          Temperature : 260 ± 5 ℃ 温度:260±5℃          Immersion duration : 10 ± 1 sec. 浸泡时间:10±1秒</p> <p>for manual soldering :手动焊接:          mil-std-202f,method 210 A,test condition A          Pre-heat : No预热:没有          Temperature : 350 ± 10 ℃ 温度:350±10℃          Immersion duration : 3.5±0.5 sec.浸泡时间:3.5±0.5秒</p>	<p>No physical damage shall occur.          不可有损坏</p>
			

Note 1: Shall meet visual requirements, show no physical damage, and meet requirement of additional tests as specified in the test sequence in Figures 2  
 说明1: 测试要求不能有物理损坏, 测试依据表格二的顺序进行

3.Product Qualification And Requalification Test:产品测试顺序表 Figure 2

Test or Examination	Test Group													
	A	B	C	D	E	F	G	H	I	J	K	L	M	N
Test Sequence														
4.1.1.Examination of Product 产品外观	1,9	1,3	1,5	1	1,5	1,5	1,5	1,3	1,5	1,5	1,5	1,5	1,5	1
4.2.1.Contact Resistance 接触阻抗	2,8		2,4		2,4	2,4	2,4		2,4	2,4	2,4	2,4	2,4	
4.2.2.Dielectric Withstanding Voltage	3,7													
4.2.3.Insulation Resistance 绝缘阻抗	4,6													
4.3.1.Insertion/Withdrawal force 插拔力		2												
4.3.2.Durability 寿命测试			3											
4.3.3.Vibration 振动性					3									



4.3.4.Physical shock 冲击性						3								
4.4.1.Thermal shock test 冷热冲击							3							
4.4.2.Solderability 焊锡性								2						
4.4.3.Humidity 恒温恒湿	5								3					
4.4.4.Salt Spray 盐水喷雾										3				
4.4.5.Cold resistance 冷阻抗											3			
4.4.6.Heat resistance 热阻抗												3		
4.4.7.Thermal Aging 高温老化													3	
4.4.8.IR-reflow 回流焊测试														2
NO. of Test samples(Min.) 测试样	5	5	5	5	5	5	5	5	5	5	5	5	5	5
<p>NOTE 2: (a) Numbers indicate sequence in which tests are performed.  (b) Discontinuities shall not take place in this test group, during tests.</p> <p>说明 2: (a)测试依照矩阵要求数量进行。  (b)在测试中，群组测试不能间断</p>														

核准：唐竹君

制作人：魏红



四.物理測試 PHYSICAL TEST

序號 NO.	測試項目 Testing Item	測試條件 Testing Conditions	測試設備 Testing Equipment	規格 SPEC	測試記錄 Testing Result					判定 Judge	
					1	2	3	4	5	Pass	Fail
1	Salt spray test	Temperature: 35±2°C Concentration:5±1 %Duration:24H	SALT SPRAY TESTER	No Oxidation	Pass	Pass	Pass	Pass	Pass	P	
2	Resistance to soldering heat test	Temperature: 260±5°C Duration:10±1sec	OVEN	No physical damage	Pass	Pass	Pass	Pass	Pass	P	
3	Solder ability test	Temperature: 260±5°C Duration:5±0.5 sec	CONTROLLED CONSTANT-TEMP SOLDER POT	Soldering area ≥95□	Pass	Pass	Pass	Pass	Pass	P	
判定 Result		<input checked="" type="checkbox"/> 合格 (ACCEPT) <input type="checkbox"/> 不合格 (REJECT)									

核准(Approver): 欠必鋒

測試(Tester): 但芬



# 深圳市华联威电子科技有限公司

## 检验報告

首件檢驗
 入庫檢驗
 出貨檢驗
 客退檢驗
 退料檢驗
 其他
 2022年04月12日 版次:A1

料號	HD27-071B-G61018	制令單號	/		送檢單位	工程部	首件製作者	裝配						
品名	HDMI 19P/F 沉板反向高度 2.99	客戶代號	/		批 量	/	送檢時間	/						
					數 量	5PCS	確認時間	/						
抽樣標準		<input checked="" type="checkbox"/> 單次 <input type="checkbox"/> 雙次			抽樣數	AQL	CRI:0	MAJ:0.40	MIN:0.65					
MIL-STD-105E(II)		<input checked="" type="checkbox"/> 正常 <input type="checkbox"/> 加嚴 <input type="checkbox"/> 減量			( 5PCS )	ACC/REJ	0	/	/					
不良數:		CRI ( / )		MAJ ( / )		MIN ( / )		不良率(%)	/					
NO.	檢驗項目 單位:MM/G	檢測 儀器	檢 驗 記 錄					品管判定		CRI	MAJ	MIN	備注	
			1	2	3	4	5	AC	RE					
	15.00±0.20	D	15.03	15.05	15.04	15.03	15.04	√						
尺 寸 測 量	12.50+0.08	D	12.53	12.54	12.53	12.55	12.54	√						
	10.80±0.20	D	10.83	10.85	10.84	10.83	10.85	√						
	18.50±0.15	D	18.53	18.55	18.52	18.55	18.53	√						
	12.08±0.20	D	12.06	12.05	12.06	12.04	12.05	√						
	11.48±0.20	D	11.48	11.46	11.45	11.46	11.45	√						
	2.99±0.20	D	3.02	3.05	3.03	3.05	3.04	√						
檢驗依據: <input checked="" type="checkbox"/> 《工程圖紙》 <input type="checkbox"/> 《檢驗規範》 <input type="checkbox"/> 《承認書》 <input type="checkbox"/> 樣品 <input type="checkbox"/> 其它														
檢測儀器:A游標卡尺 B千分尺 C厚薄儀 D投影鏡 E放大鏡 F顯微鏡 G錫爐 H插拔力器 I間位尺 J其它														
品保判定:		<input checked="" type="checkbox"/> 合格Accept <input type="checkbox"/> 退貨Reject <input type="checkbox"/> 特采Waive <input type="checkbox"/> 挑選Sort												

核准: 欠必鋒

審核: 李娟

檢驗員: 但芬

品名: HDMI 19P/F 沉板反向高度2.99 (端子)			版次:A.0		
电镀规格:Ni40u", Sn40u", Au G/Fu"		日期:2022-03-20		页次:1/1	
厂商:同华					
测试设备:CMI X-射线膜厚测试仪					
1、底层电镀测试 (Ni)					
数据	测试标准	实测值	判定	测试日期	测试时间
1	40u"MIN	50.5u"	OK	2022/3/20	10:20:15
2	40u"MIN	56.3u"	OK	2022/3/20	10:20:17
3	40u"MIN	67.5u"	OK	2022/3/20	10:20:19
4	40u"MIN	62.4u"	OK	2022/3/20	10:20:21
2、表层电镀测试 (Sn)					
数据	测试标准	实测值	判定	测试日期	测试时间
1	40u"MIN	65.3u"	OK	2022/3/20	10:25:10
2	40u"MIN	74.7u"	OK	2022/3/20	10:25:12
3	40u"MIN	75.9u"	OK	2022/3/20	10:25:14
4	40u"MIN	70.4u"	OK	2022/3/20	10:25:16
3、表层电镀测试 (Au)					
数据	测试标准	实测值	判定	测试日期	测试时间
1	0.5u"MIN	0.56u"	OK	2022/3/20	10:30:32
2	0.5u"MIN	0.54u"	OK	2022/3/20	10:30:34
3	0.5u"MIN	0.57u"	OK	2022/3/20	10:30:36
4	0.5u"MIN	0.55u"	OK	2022/3/20	10:30:38

核准: 欠必锋

审核: 李娟

检验员: 但芬

## 电镀报告表

品名: HDMI 19P/F 沉板反向高度2.99 (外壳)		版次:A.0			
电镀规格:Ni:50u" min		日期:2022/2/16	页次:1/1		
厂商:金和源					
测试设备:CMI X-射线膜厚测试仪					
1、表层电镀测试 (Ni)					
数据	测试标准	实测值	判定	测试日期	测试时间
1	50u"min	56.3u"	OK	2022/2/16	10:42:14
2	50u"min	58.6u"	OK	2022/2/16	10:42:16
3	50u"min	55.4u"	OK	2022/2/16	10:42:18
4	50u"min	54.5u"	OK	2022/2/16	10:42:20

核准: 欠必锋

审核: 李娟

检验员: 但芬

## 盐水喷雾实验报告

试验方法	盐水喷雾腐蚀试验法	参考资料	MIL-STD-1216
METHOD	NEUTRL SALT SPRAY CORROSION TEST	REF	
客户	/	试验起始日期	2022年04月10日 20:00 时起
		DATE	2022年04月11日 20:00 时止
样品名称	HDMI 19P/F 沉板反向高度2.99	试验数量	5PCS
P/N	HD27-071B-G61018		

## 试验条件 (TEST CONDITION)

- 1、盐水溶解 (SALT SOLUTION: 浓度 $50 \pm 10\text{g/L}$ , PH值6.5-7.2).
- 2、试验室温度 (TEMP. IN THE SPRAY CHAMBER):  $35 \pm 1^\circ\text{C}$ .
- 3、盐水桶温度 (TEMP. OF SALT SOLUTION TANK):  $35 \pm 1^\circ\text{C}$ .
- 4、压力桶温度 (TEMP. OF AIR SUPPLY):  $47 \pm 1^\circ\text{C}$ .
- 5、试验室相对湿度 (R. H IN THE CHAMBER) 85%.
- 6、压缩空气压力 (COMPRESSED AIR PRESSURE):  $1.00 \pm 0.01\text{Kg/cm}^2$ .
- 7、样品放置位置 (SPECIMEN SUPPORTED ANGLE): 尼龙绳吊挂 $70^\circ - 90^\circ$ .
- 8、喷雾收集量 (COLLECT RATE OF SALT SOLUTION)  $1-2\text{mL}/(8\text{ cm}^2\text{hr})$ .
- 9、盐雾测试时间: 24小时 (H)

## 判定方法 (ADJUSTED METHOD)

试验后以20倍放大镜观察、无蓝、绿色腐蚀物之现象 (不包含折弯处), 即判定合格. (Inspect the specimen at 20 magnification no blue or green corrosion products are acceptable)

样品序号	试验后现象	判定
	PHENOMENON AFTER TEST	COMMENT
1	无蓝、绿色腐蚀物之现象	OK
2	无蓝、绿色腐蚀物之现象	OK
3	无蓝、绿色腐蚀物之现象	OK
4	无蓝、绿色腐蚀物之现象	OK
5	无蓝、绿色腐蚀物之现象	OK

核准: 欠必锋

审核: 李娟

试验员: 但芬

## Materials Information

**PRODUCT NAME: LCP M-401 BK**

**COMPOSITION/INFORMATION OF LCP M-401 BK**

**SUBSTANCE/MIXTURE: Mixture**

**SYNONYM(S): Aromatic Liquid Crystal Polymer(LCP)**

品名	比例	用途
德众泰 LCP 树脂	0.565	构成材料主要成分
抗氧化剂	0.002	抗氧化
科莱恩热稳定剂	0.003	增加高温稳定性
黑色母	0.01	着色
滑石粉	0.2	增强剂, 增加流动性
玻纤	0.22	增强

NAME OF COMPANY: DZT Engineering Plastics Tech. Co.,Ltd

ADDRESS: Building 2 Zhichong Industrial Park, Hi-Tech Zone, Jiangmen City,  
Guangdong Province, China

SECTION IN CHARGE: Quality Assurance Department

TEL/FAX: +86-750-3689920/+86-750-3689921

EMERGENCY TEL: +86-750-3689708





# 材 质 证 明 书 (2020/A)

## MATERIAL CERTIFICATE

生产厂家		SHNZHEN CITY XINQIA METAL PRODUCTS CO. LTD				生产编号		B20191101		开立日期		2019.11、5		证明书编号		20191105-01	
钢种名称		SUS 304 1\2H				订单编号		JIS		依据规范							
Order No						By Standard											
项目 Item	钢卷编号 Coil No	厚度(mm) Thickness	宽度(mm) Width	长度 Length	数量(卷) Quantity©	重量(Kg) Weight (Kg)		成品表面加工									
1		0.3	296	COIL	1	1400											
2																	
3																	
4																	
5																	
6																	
化学成份Chemical Composition (%)											标准 Spec	硬度 Hardness	降伏强度 (N/mm <sup>2</sup> ) Yield stress	引张强度 (N/mm <sup>2</sup> ) Tensile Stress	伸长率(%) Elongation	弯曲试验 Bend Test	
C	Si	Mn	P	S	Cr	Ni	Mo	N									
标准 Spec	0.080 max	0.750 max	2.000 max	0.045 max	0.030 max	18.00 20.00	8.00 10.50				试片编号 Specimen	270-290HV	865 min	1059 min	- -		
1	0.042	0.320	1.180	0.031	0.006	18.03	8.01				20140328-01	270	497	870	-	OK	
2																	
3																	
4																	
5																	
6																	
以上列出的典型数据,仅供参考,并不代表技术数据的最大值或最小值,也不用于最终设计.任一具体材料的数据可能与此表中所列出的数据有所不同. Data shown are typical,For reference only,and should not be construed as maximum or minimum values for specification or for final design data. On any particular piece of material may vary from those shown herein.												如有异常,请于三天内回复 Only discrepancy pls contact us within 3 days				 技术部经理 Manager	

# 鉅鼎銅材廠檢驗報告單

公司名稱 Customer	鉅鼎銅材廠檢驗報告單				重量 Weight(kg)	1078	出貨日期 Date	2021/11/23		
品名 Article	標準 Standard No				尺寸 Dimension		狀態 Tenper	銅卷編號 Coil No		
C2680	JISH3100:2017				0.18*400		EH	1021-C-08		
化學成分Chemical Compositions(%)										
元素 Element	Cu %	Zn%	Pb%	Fe%	\	\	\	\	化學成分	雜質
規範 Spec	64.0-68.0	餘量	<0.05	<0.05	\	\	\	\	合格	合格
實測 Actual	64.32	餘量	0.0036	0.0136	\	\	\	\	合格	合格
機械性質Mechanical Properties										
項目 Item	結晶粒度 Grain Size Mm	硬度 Hardness Hv	抗拉強度 TensionStrength Mpa	伸長度 Elongation %	導電率 Electrical Conduc %IACS	彎曲試驗 Bending Test 180	表面粗度 Surface Roughness Ra(u m)	彎曲度 Camber mm/n		
規範MAX Spec	\	170-190	490-610	\	\	\	\	\		
實測 Actual	\	178	574	5	\	\	\	\		

品質部

