

REV.	ECN.NO.	APPD.
A	XXXXXXXXXX	Hexing

- NOTES:
- MATERIAL:
    - Housing:thermoplastic plastics
    - terminals:Copper Alloy  
Gold plated in contact area:  
Tin plated in termination  
Nickel Plated overall
    - Shell:Steel&Copper Alloy  
Nickel Plated overall
  - ELECTRICAL CHARACTERISTICS:
    - Rating Current :1.5 Ampere
    - Rating Voltage :30 V Max
    - Contact Resistance:50 Milli ohms
    - Insulation Resistance:100 Mega ohms Min.
  - MECHANICAL CHARACTERISTICS:
    - Connector Mating force: 35N MAX(3.57Kgf)
    - Connector Unmating force:10N min(1.02Kgf)
    - Durability:1500Cycles.
  - ENVIRONMENT CHARACTERISTICS:
    - Operating temperature:-0°C to +50°C
    - Storage temperature:-20°C to +60°C

ND21-0111-161011

1:铁壳镀镍  
1:1u"Au  
1:吸塑盒  
1:黑色  
6:LCP

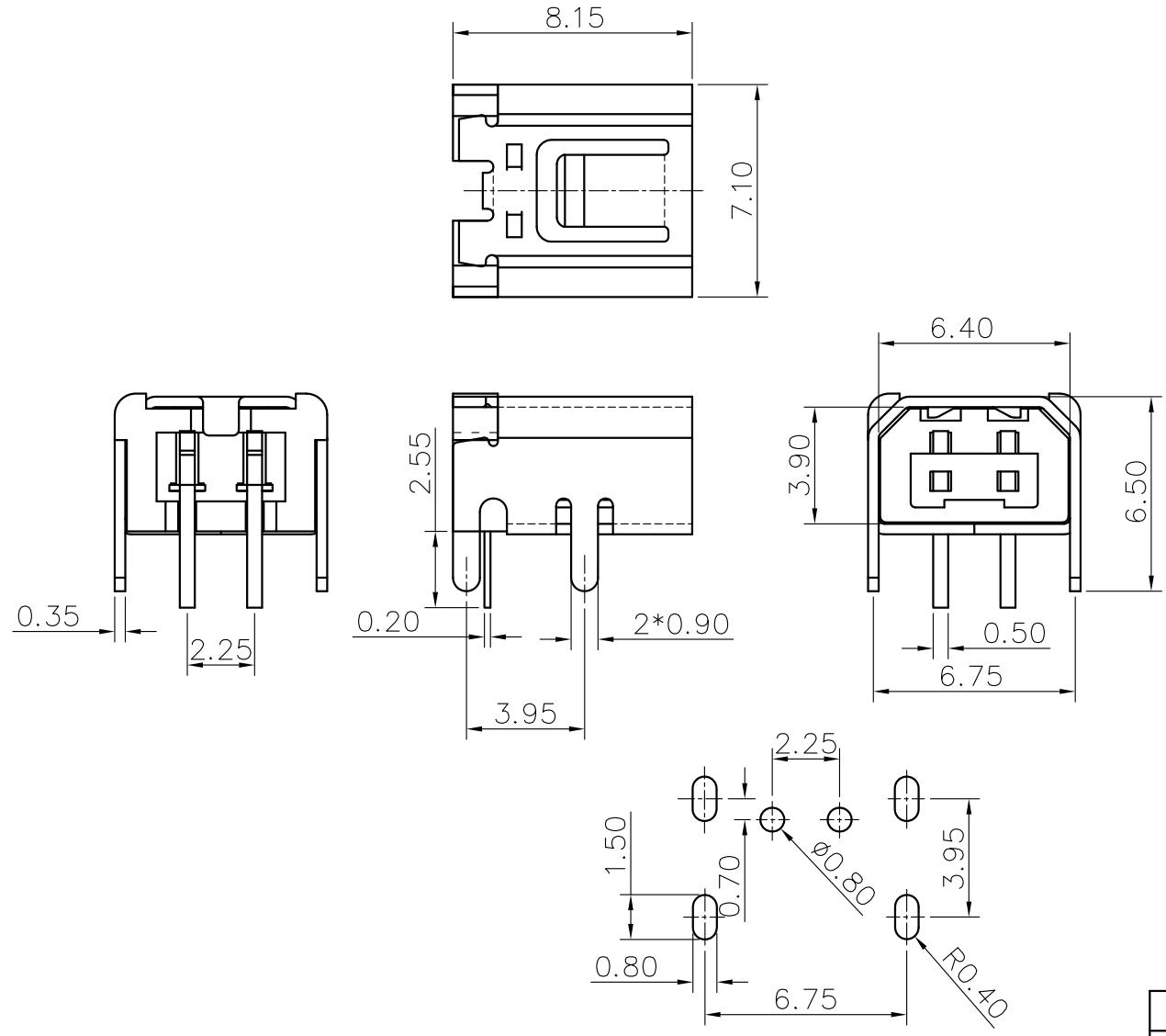

TOLERANCE UNLESS OTHERWISE SPECIFIED		<b>FLW</b> 深圳市华联威电子科技有限公司				
.XXX ±0.10 .XX ±0.20 .X ±0.30		HUA LIAN WEI TECHNOLOGY ELECTRONICS				
.X' ±3' .XX' ±2'		PART NAME:		NDSI 2P/F		
APPROVED		PART No:		ND21-0111-161011		C
CHECKED		PROJECTION:		UNIT:	SCALE:	SHEET:
DRAWN	luwenqi	DATE		mm	1:1	10F1
DATE	2015.05.25					A