

REV.	ECN.NO.	APPD.
A	/	/

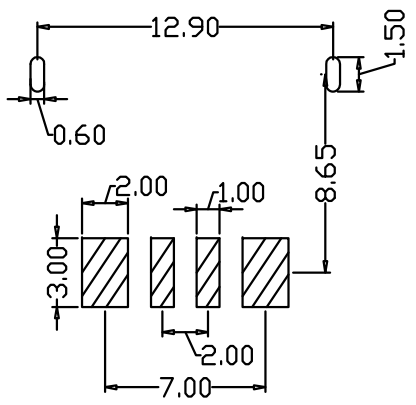
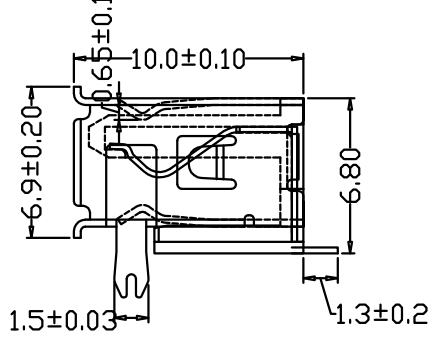
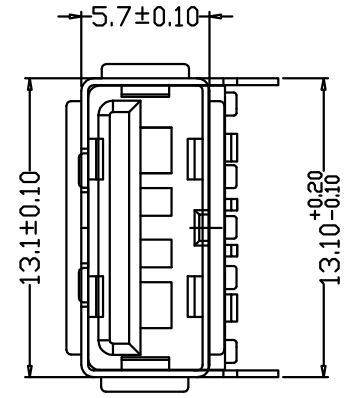
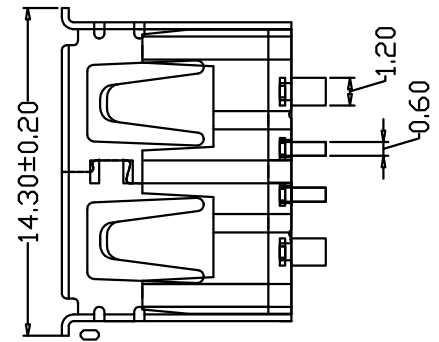
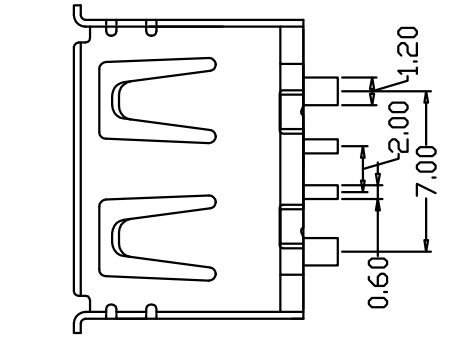

NOTES:

- 1.MATERIAL:
 - 1.1 Housing:thermoplastic plastics
 - 1.2 terminals:Copper Alloy
Gold plated in contact area:
Tin plated in termination
Nickel Plated overall
 - 1.3 Shell:Steel&Copper Alloy
Nickel Plated overall
- 2.ELECTRICAL CHARACTERISTICS:
 - 2.1 Rating Current :1.5 Ampere
 - 2.2 Rating Voltage :30 V Max
 - 2.3 Contact Resistance:30 Milli ohms
 - 2.4 Insulation Resistance:1000 Mega ohms Min.
- 3.MECHANICAL CHARACTERISTICS:
 - 3.1 Connector Mating force: 35N MAX(3.57KgF)
 - 3.2 Connector Unmating force:10N min(1.02KgF)
 - 3.3 Durability:1500Cycles.
- 4.ENVIRONMENT CHARACTERISTICS:
 - 4.1 Operating temperature:-0°C to +50°C
 - 4.2 Storage temperature:-20°C to +60°C

U222-3531-G61018
 1:铁壳镀镍
 1:吸塑盒
 1:黑色
 6:LCP
 G:半金G/Fu"

TOLERANCE UNLESS OTHERWISE SPECIFIED		FLW 深圳市华联威电子科技有限公司				
.XXX ±0.10 .XX ±0.20 .X ±0.30		.X' ±3' .XX' ±2'		HUA LIAN WEI TECHNOLOGY ELECTRONICS CO;LTD.		
APPROVED		PART NAME:	USB AF 短体10.0 两脚插			
CHECKED		PART No:	U222-3531-G61018			C
DRAWN	weihong	PROJECTION:	UNIT:	SCALE	SHEET	REV.
DATE	2021.11.06		mm	1:1	10F1	A