

REV.	ECN. NO.	APPD.
A	/	ZFY

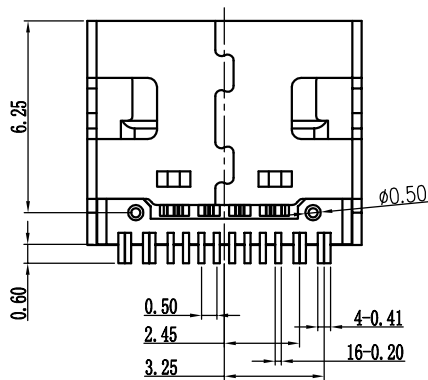
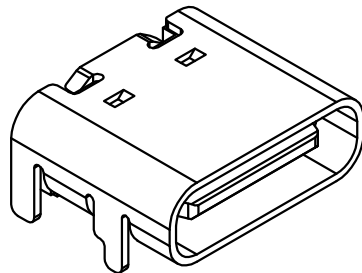
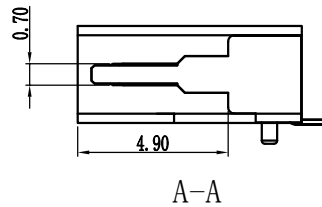
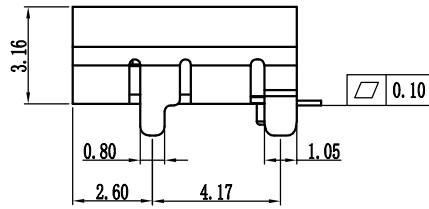
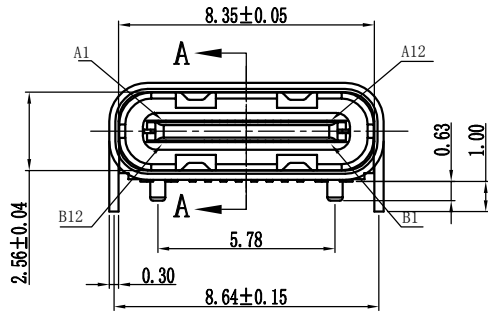
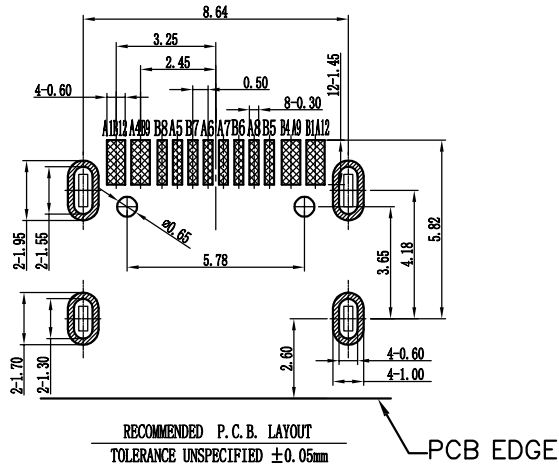
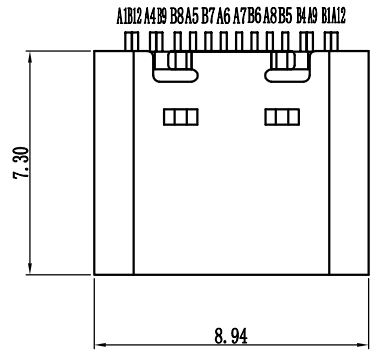

NOTES:

1. MATERIAL:

- 1.1 Housing:thermoplastic plastics
- 1.2 terminals:Copper Alloy  
Gold plated in contact area:  
Tin plated in termination  
Nickel Plated overall
- 1.3 Shell:Steel&Copper Alloy  
Nickel/Au Plated overall

2. characteristics:

- 2.1 Rating Voltage : 30V AC.
  - 2.2 Rating Current:  
5A for Vbus PIN;1.25A for Vconn PIN
  - 2.3 Contact Resistance:40 mΩ MAX.
  - 2.4 Insulation Resistance:100 MΩ MIN.
  - 2.5 Withstanding Voltage:AC 100V
  - 2.6 Mating force: 5~20N MAX
  - 2.7 Extraction force:8~20N Min
  - 2.8 Life test:10000Cycles MIN.
  - 2.9 Temperature Range: -30℃~+80℃.
- The product must be compliance ROHS

U572-402B-G63038

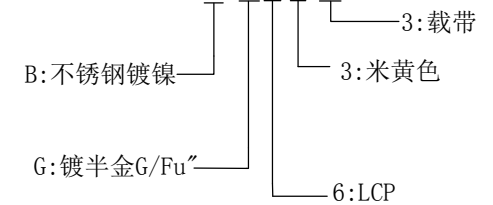

TOLERANCE UNLESS OTHERWISE SPECIFIED		FLW 深圳市华联威电子科技有限公司 HUA LIAN WEI TECHNOLOGY ELECTRONICS CO;LTD.						
.XXX ±0.15	.X' ±5'	APPROVED	PART NAME:	TYPE C 16P/F 四脚插				
.XX ±0.20	.XX' ±2'	CHECKED	PART No:	U572-402B-G63038			C	
.X ±0.30		DRAWED	ZhangFenYan	PROJECTION:	UNIT:	SCALE	SHEET	REV.
		DATE	2018. 10. 10		mm	1:1	10F1	A