

REV.	ECN.NO.	APPD.
A0	/	/

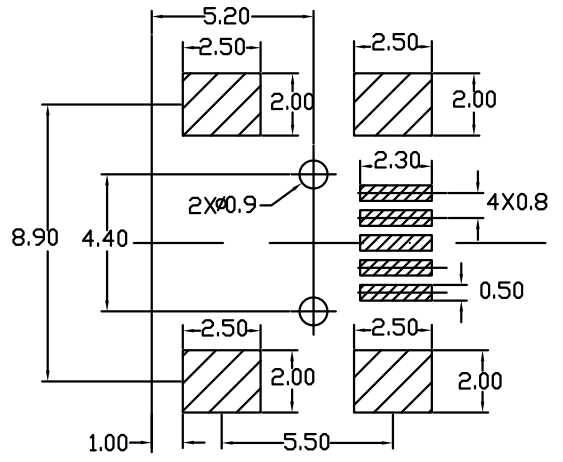

RECOMMENDED PCB LAYOUT

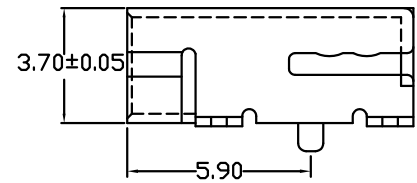
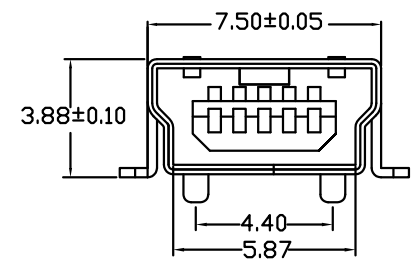
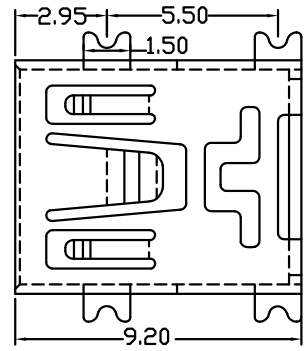
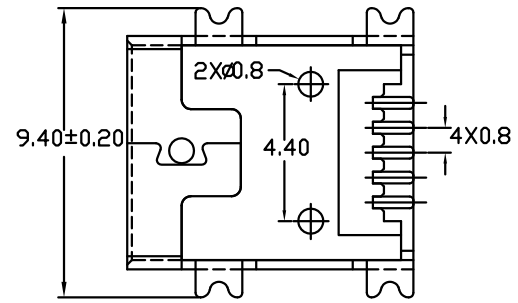

NOTES:

1.MATERIAL:

- 1.1 Housing: thermoplastic plastics,
- 1.2 terminals:Copper Alloy
Gold plated in contact area:
Tin 40u”min plated in termination
Nickel Plated overall
- 1.3 Shell:Steel&Copper Alloy
Nickel/Tin Plated overall

2.ELECTRICAL CHARACTERISTICS:

- 2.1 Rating Current :1.5 Ampere
- 2.2 Rating Voltage :30 V Max
- 2.3 Contact Resistance:50 Milli ohms
- 2.4 Insulation Resistance:100 Mega ohms Min.

3.MECHANICAL CHARACTERISTICS:

- 3.1 Connector Mating force: 35N MAX
- 3.2 Connector Unmating force:7N min

4.ENVIRONMENT CHARACTERISTICS:

- 4.1 Operating temperature:-0°C to +50°C
- 4.2 Storage temperature:-20°C to +60°C

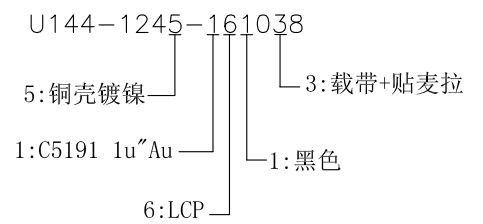

TOLERANCE UNLESS OTHERWISE SPECIFIED		FLW 深圳市华联威电子科技有限公司 HUA LIAN WEI TECHNOLOGY ELECTRONICS CO;LTD.				
.XXX ±0.10	.XX ±0.20	.X ±0.30	.X ±3'	.XX ±2'		
APPROVED		PART NAME:	MINI 5P/F SMT 0.3黑铜			
CHECKED		PART No:	U144-1245-161038	C		
DRAWN	chenyiting	PROJECTION:	UNIT:	SCALE	SHEET	REV.
DATE	2023.06.25		mm	1:1	10F1	A0