

REV.	ECN.NO.	APPD.
A	/	/

NOTE:

- MATERIAL:
HOUSING: LCP WITH 30% GF, UL 94V-0, BLACK COLOR.
CONTACTS: PHOSPHOR BRONZE.
BOARDLOCKS: BRASS.
- FINISH:
CONTACTS: GOLD FLASH PLATED ON CONTACT AREA, [100μ"] MIN..
BRIGHT-TIN ON SOLDER TAIL, WITH ENTIRE CONTACT UNDERPLATED [50μ"] MIN.. NICKEL.
BOARDLOCKS: [100μ"] MIN. BRIGHT-TIN OVER[50μ"] MIN. NICKEL ON ENTIRE BOARDLOCK.
- PART NUMBER DESCRIPTION :

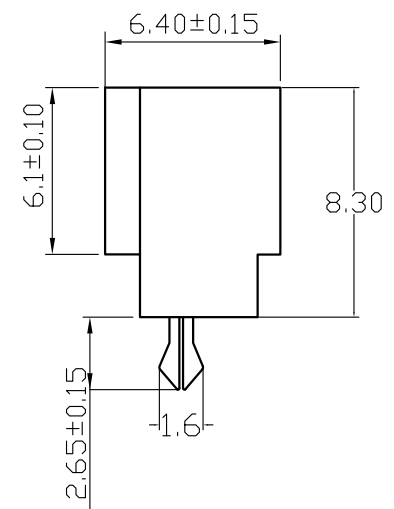
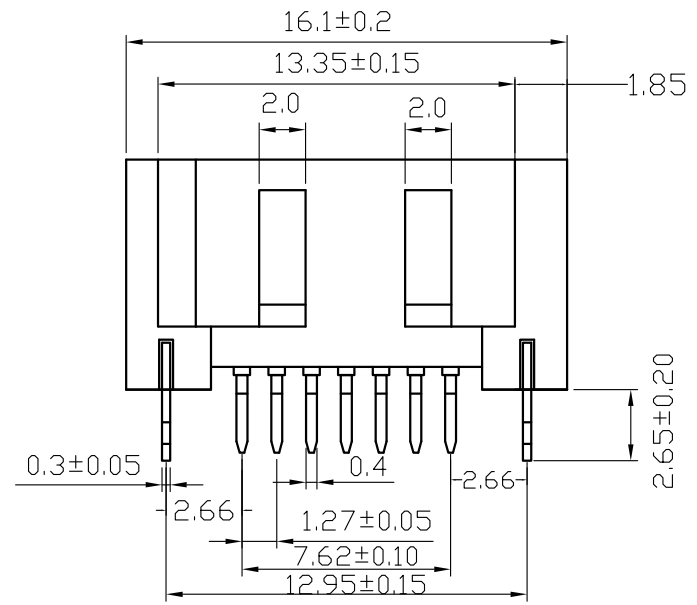
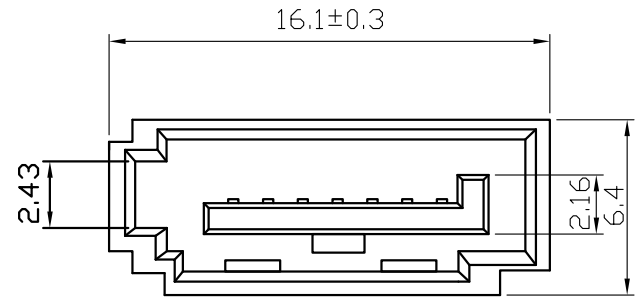

ST12-0341-G618

G:半金G/FU" 1:黑色
6:LCP

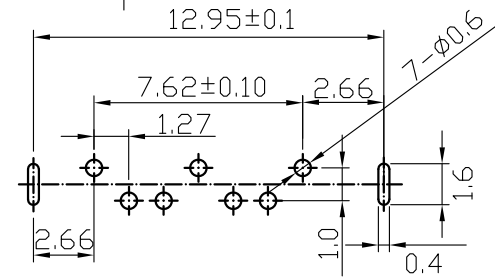
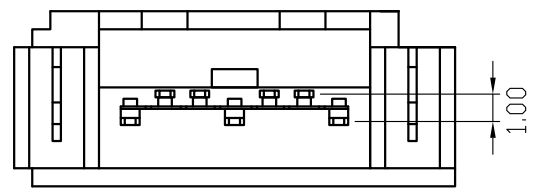

P. C. B Layout

TOLERANCE UNLESS OTHERWISE SPECIFIED		FLW 深圳市华联威电子科技有限公司			
.XXX ±0.10 .XX ±0.20 .X ±0.30		.X* ±3' .XX* ±2'		HUA LIAN WEI TECHNOLOGY ELECTRONICS CO;LTD.	
APPROVED		PART NAME:	SATA-7P 公头 立式 全塑		
CHECKED		PART No:	ST12-0341-G618	C	
DRAWN	chenyiting	PROJECTION:	UNIT:	SCALE	SHEET
DATE	2022.04.19		mm	1:1	10F1
					REV. A