

REV.	ECN.NO.	APPD.
A	/	/

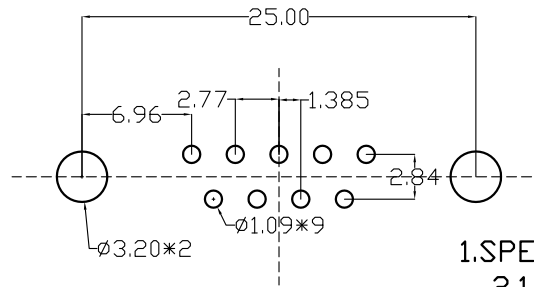
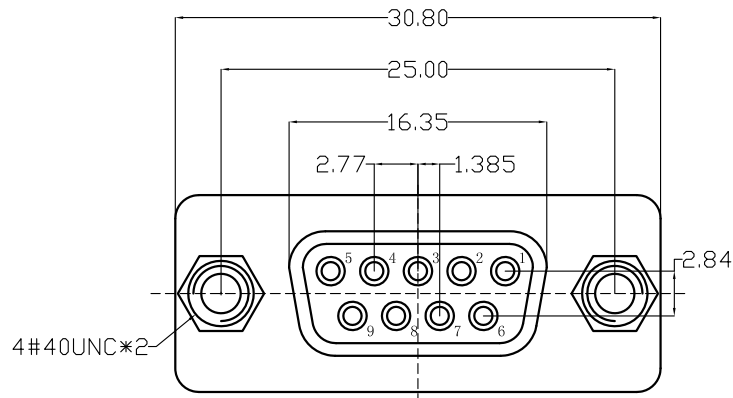

P.C.B LAYOUT

1.SPECIFICATION

- 2.1 Current Rate:5 Amps
- 2.2 Insulator Resistance:1000MΩ Min.
- 2.3 Dielectric Strength:500V AC PER MIN
- 2.4 Operation Temperature:-55℃~+105℃
- 2.5 Contact Resistance:30mΩ Max

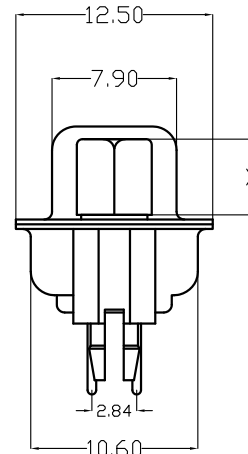
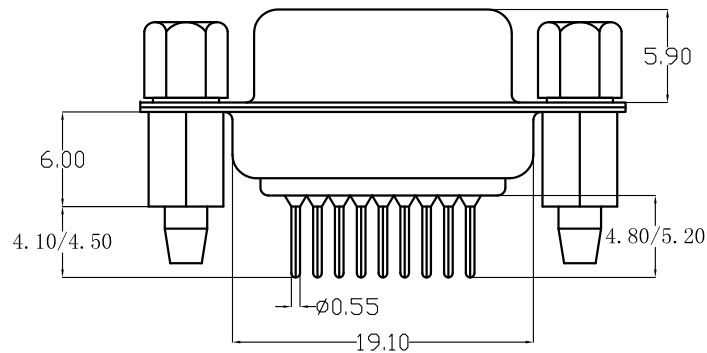

DS412-1711-XXX7

G. 半金G/FU" B. 白色

2. PBT

螺丝规格

	零件编号	X尺寸	内牙
	5	4.8	4#40
	6	5.8	4#40

TOLERANCE UNLESS OTHERWISE SPECIFIED		<b>FLW</b> 深圳市华联威电子科技有限公司 HUA LIAN WEI TECHNOLOGY ELECTRONICS CO;LTD.			
.XXX ±0.10	.XX ±0.20	.X ±0.30	.X' ±3'	.XX' ±2'	
APPROVED		PART NAME:	DP 9母柳锁		
CHECKED		PART No:	DS412-1711-G2B7	C	
DRAWN		PROJECTION:	UNIT:	SCALE	SHEET
DATE			mm	1:1	10F1
					REV. A